

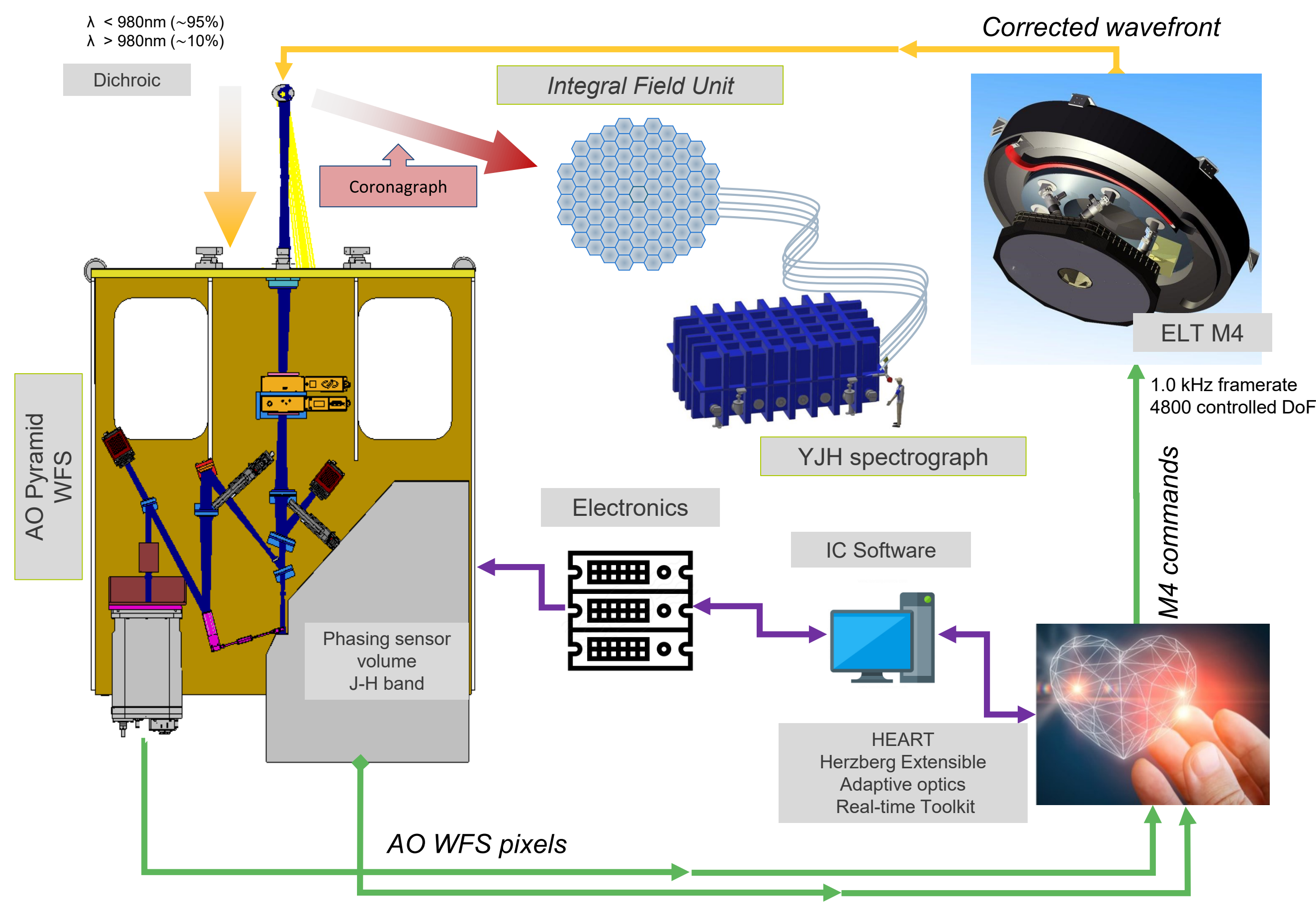

The Single Conjugated Adaptive Optics system of ANDES

E. Pinna^{1,A,B}, C. Selmi^{A,B}, J. P. Véran^F, G. Carlà^{A,B}, A. Simonnin^F, M. N'Diaye^{C,D}, G. Agapito^{A,B}, P. Berio^{C,D}, A. Spang^{C,D}, G. Chauvin^G, A. Chiavassa^{C,D}, V. Parmentier^{C,D}, F. Rossi^{A,B}, J. Seidel^{C,D}, P. Martinez^{C,D}, N. Azzaroli^{A,B}, E. Redaelli^A, V. Baldini^A, G. Calderone^A, E. Chapin^F, C. Plantet^{A,B}

Adaptive optics system



Looking for exo-planet in reflected light

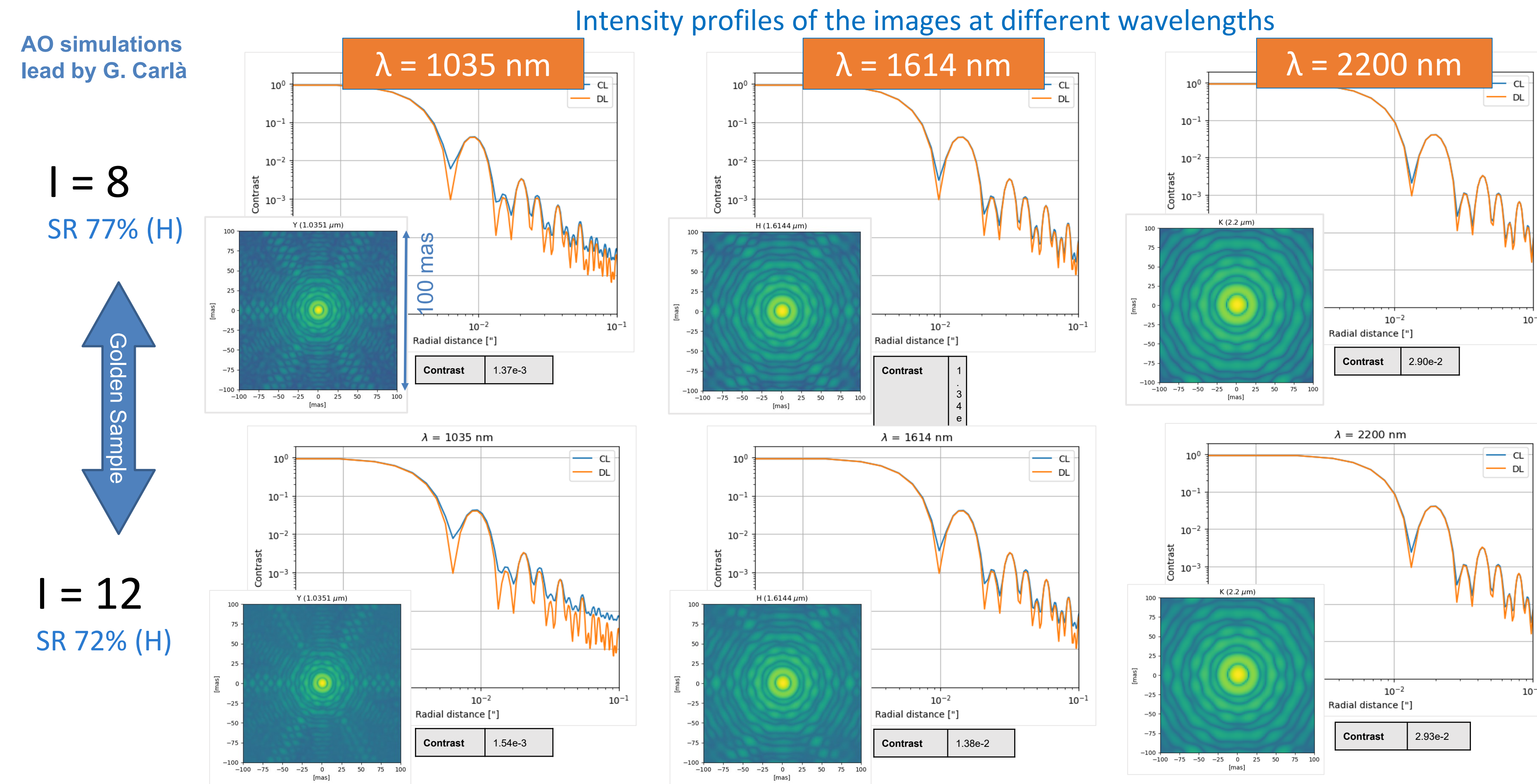

Let's move to fainter targets

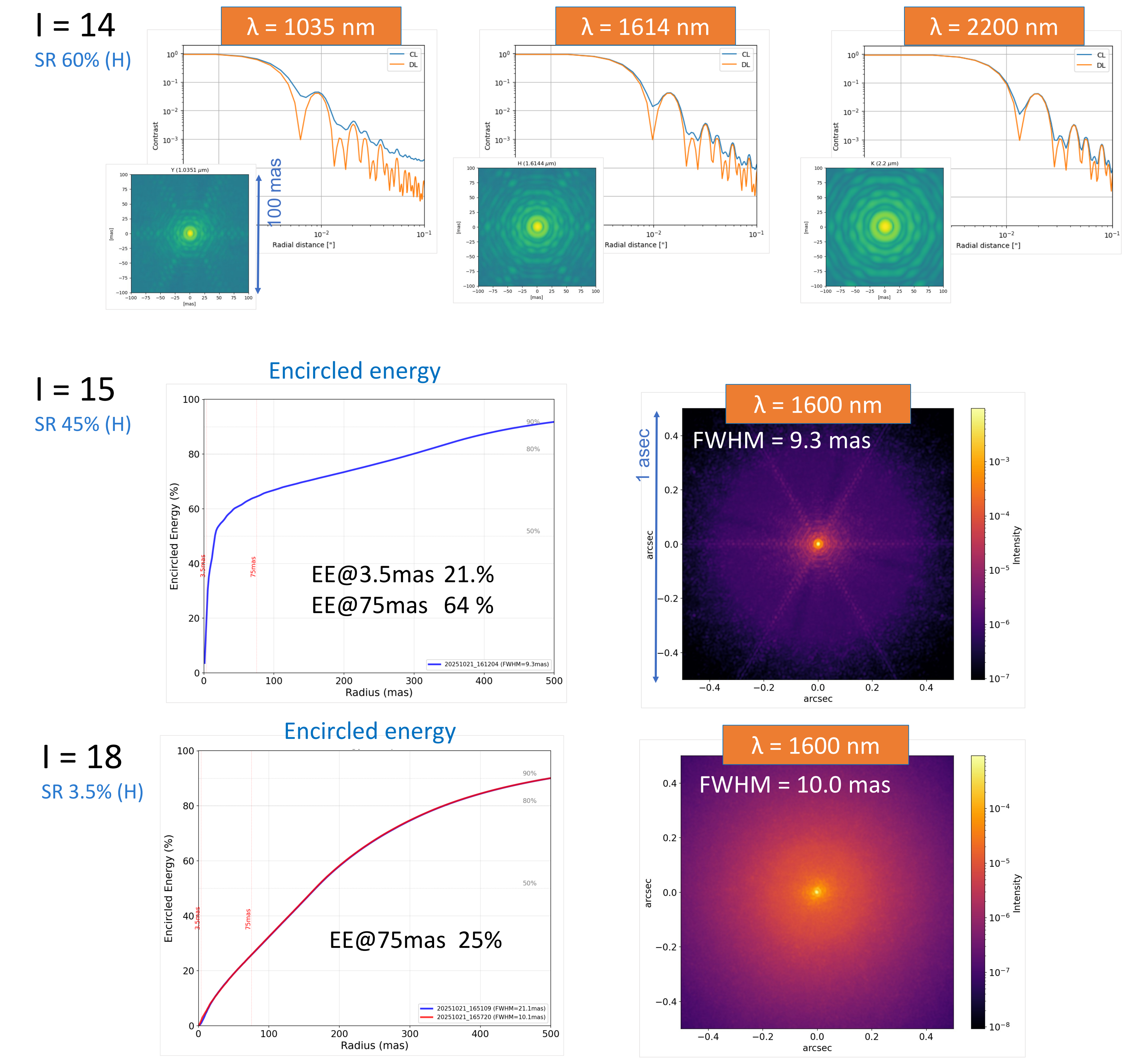

Coronagraph

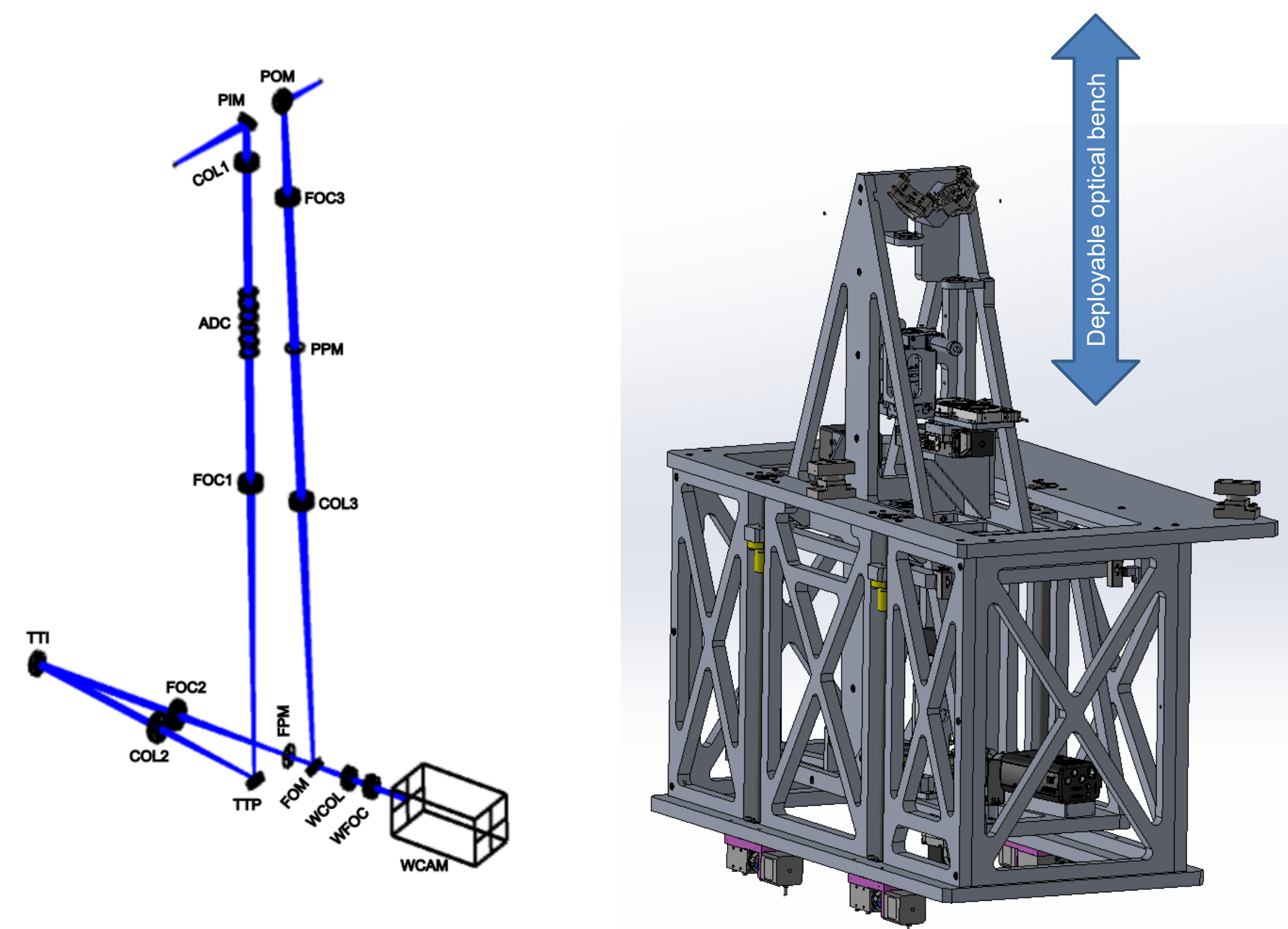

Coro simulation lead by M. N'Diaye & A. Chiavassa

With Coronagraph Intensity profiles of the images at different wavelengths

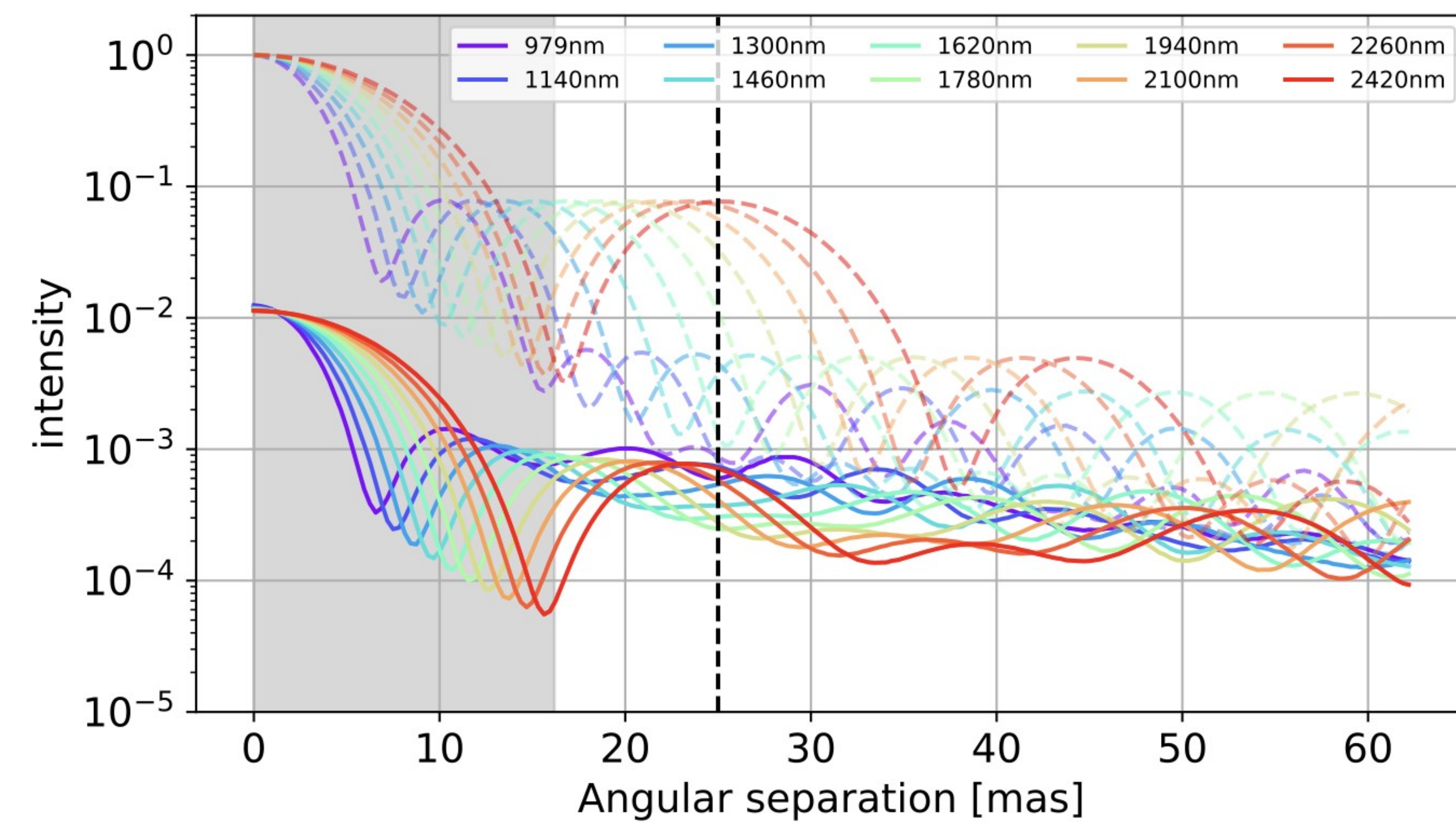

Is this interesting for your science?

- What are the target characteristics? (magnitude of the star and distance of the target)
- What are the needed performance to reach the scope? (SR; FWHM; contrast)

¹ Contact: enrico.pinna@inaf.it



Meeting della strumentazione ELT a guida italiana (MORFEO e ANDES)

12-15 May 2026

INAF-Osservatorio Astronomico di Capodimonte