

# High spatial resolution observations of MYSOs in the NIR

## **IRAS20126+4104 and (some) other sources**

F. Massi  
INAF-Arcetri

Riccardo's workshop – Florence, May 2026

# High spatial resolution observations of MYSOs in the NIR

**IRAS20126+4104, aka Ric's Pet, aka Bigné**

Distance 1.64 pc from maser parallaxes (Moscadelli et al. 2011)

Protostar mass  $\sim 12 M_{\text{sun}}$  (Cesaroni et al. 2014, Chen et al. 2016)

$L \sim 10^4 L_{\text{sun}}$

Jet + circumstellar disc (NIR, interferometric mm observations)

Jet precession



# High spatial resolution observations of MYSOs in the NIR

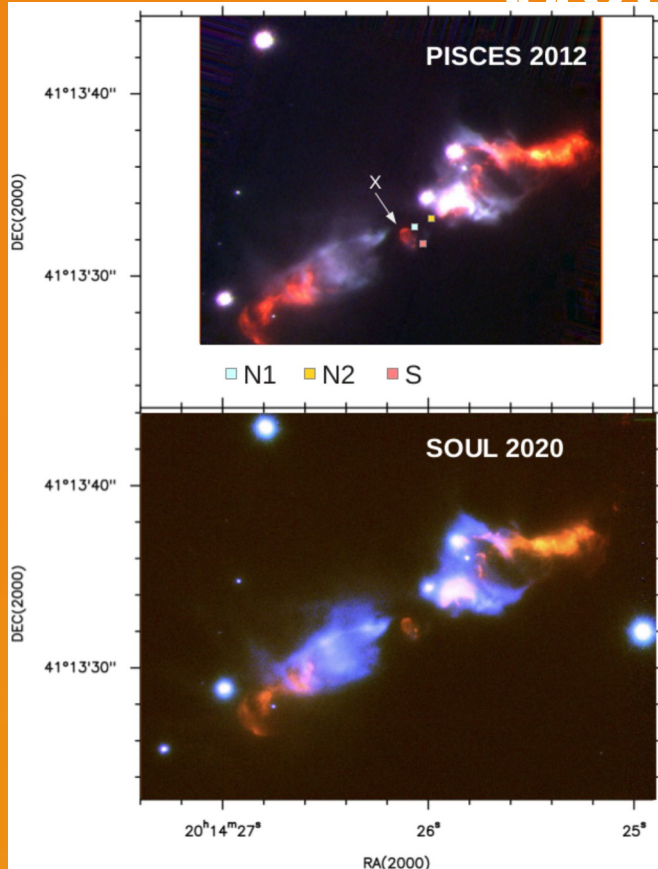

IRAS20126+4104  
Adaptive optics (res. 0".1)

Red: H2 filter  
Green: Ks filter  
Blue: Bry filter

PISCES+FLAO@LBT (Cesaroni et al. 2012)  
LUCI1+SOUL@LBT (Massi et al. 2023)

From Massi et al. 2023, A&A 672, A113

Riccardo's workshop – Florence, May 2026

# High spatial resolution observations of MYSOs in the NIR

CIAO Data  
Sridharan et al. 2007

Radial velocities  
Caratti o Garatti et al.  
2008

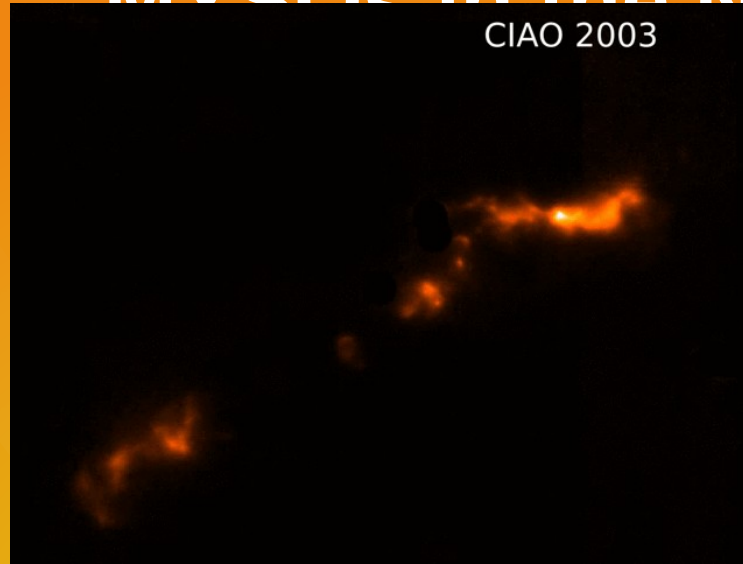

Proper motions (3 epochs, 2003, 2012, 2020)

$\langle V_t \rangle = 80 \pm 30$  km/s  $\langle V_{tot} \rangle = 45 - 134$  km/s  
 $i = 76 - 98$  deg,  $\langle i_{sky} \rangle = 8 \pm 1$  deg

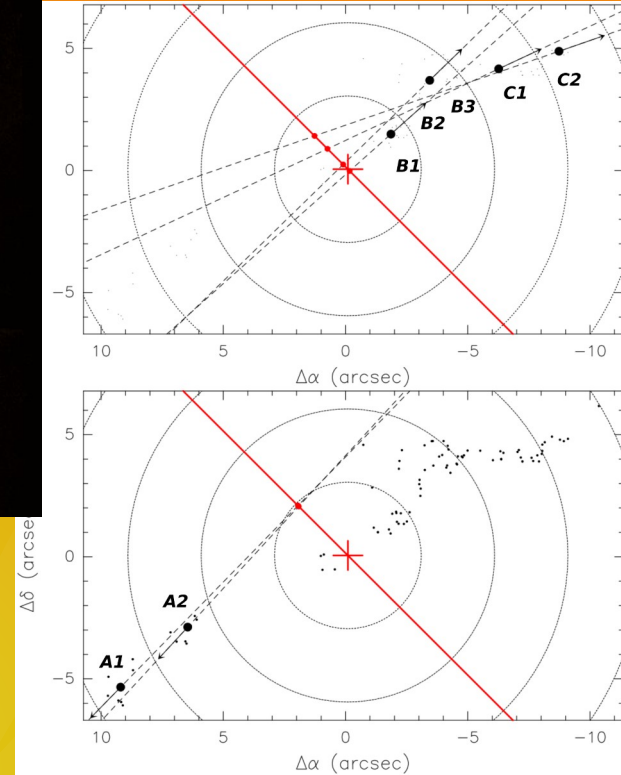

Riccardo's workshop – Florence, May 2026

# High spatial resolution observations of Ds in the NIR

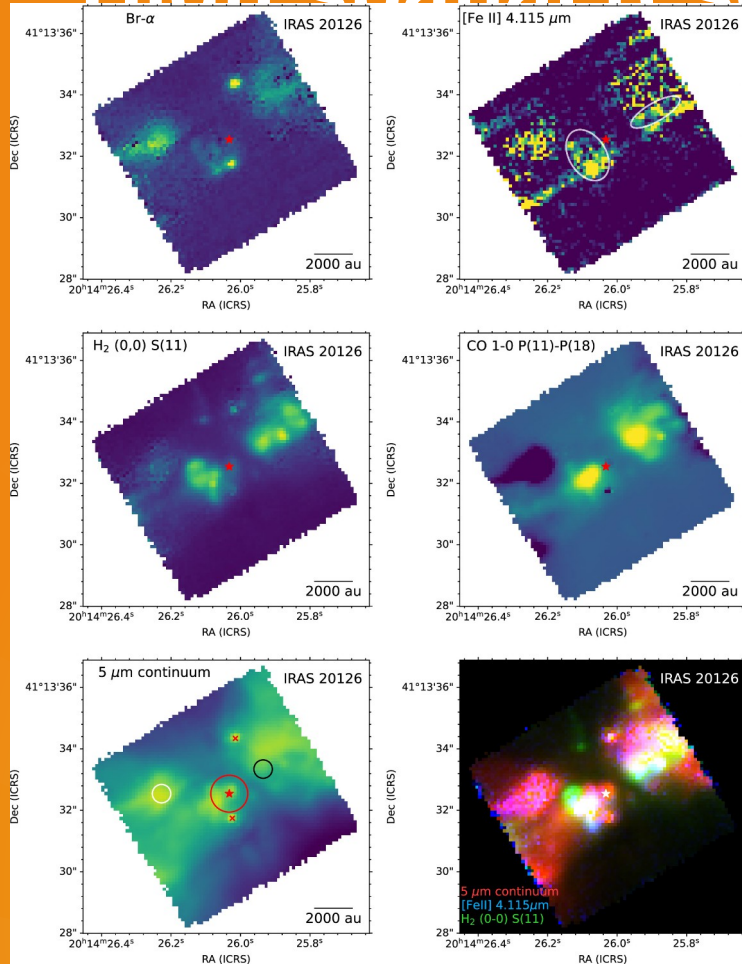

NIRSpec+MIRI@JWST

Spatial resolution  $\sim 0''2$

Note that the ring-like emissio seen  
In H<sub>2</sub> is now imaged in the NIR continuum  
and other lines: SE opening of cavity

(Federman et al., 2024, ApJ 966, 41)

Riccardo's workshop – Florence, May 2026

# High spatial resolution observations of MYSOs in the NIR

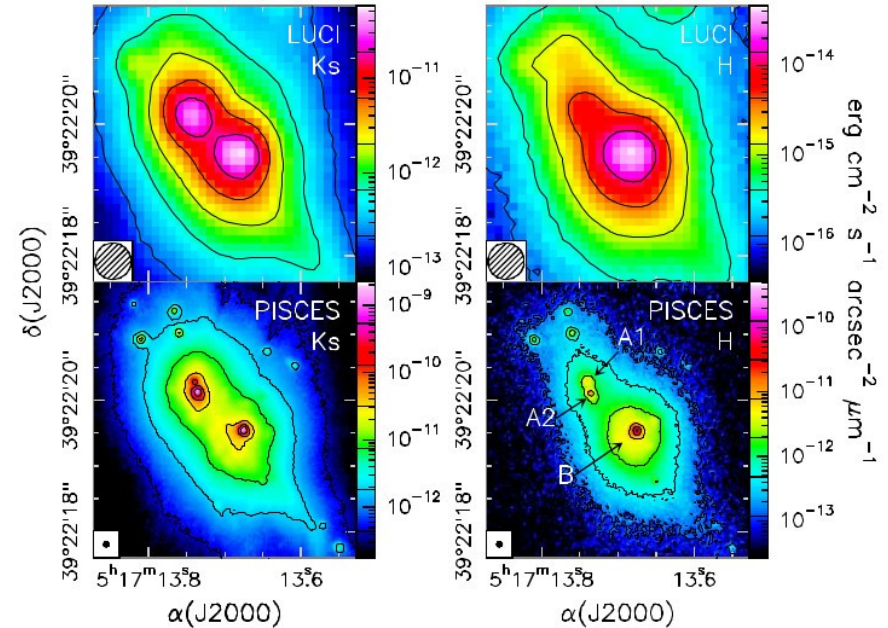
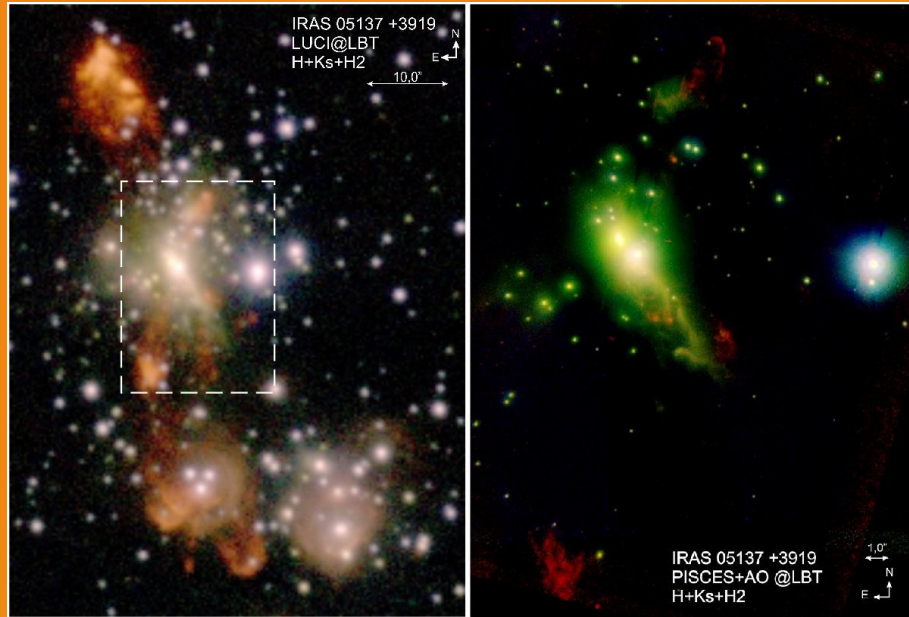

IRAS05137+3919  $d \sim 8.3$  kpc,  $L(A+B) \sim 2.4 \times 10^4 L_{\text{sun}}$   
 (Cesaroni et al. 2015, A&A 581, A14)

PISCES+FLAO@LBT  
 (res  $\sim 0''.08$ )

Riccardo's workshop – Florence, May 2026

# High spatial resolution observations of MYSOs in the NIR

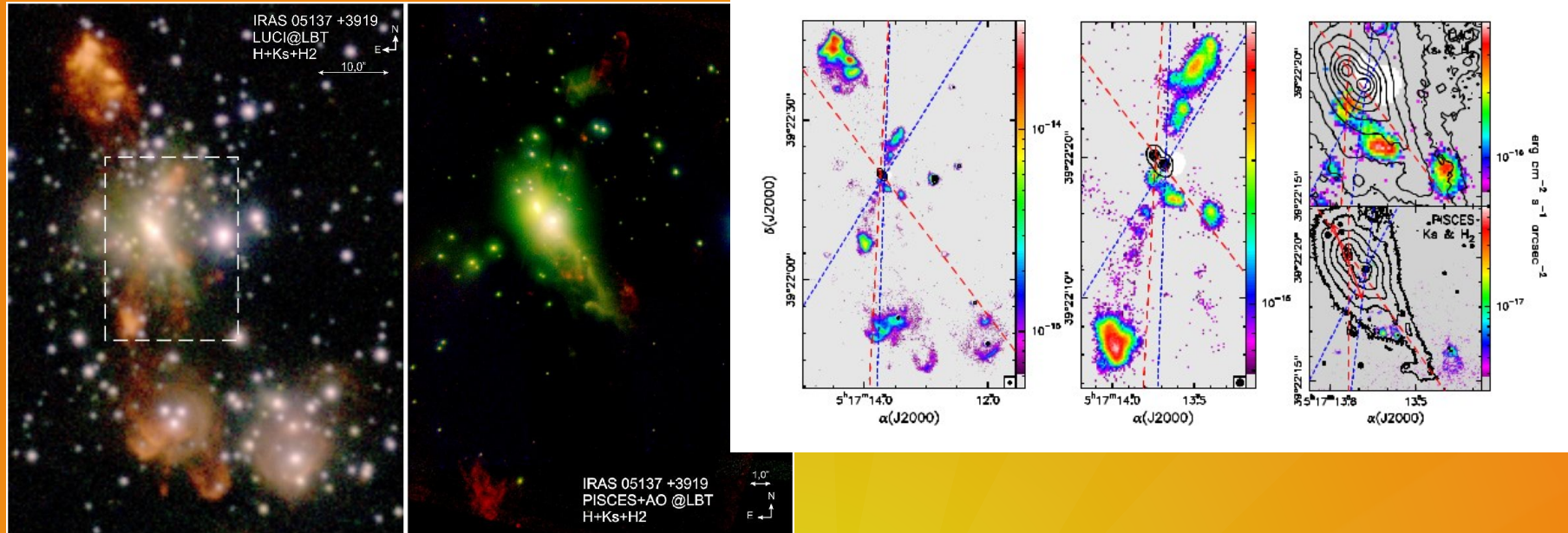

IRAS05137+3919  $d \sim 8.3$  kpc, (Cesaroni et al. 2015, A&A 581, A14)

Riccardo's workshop – Florence, May 2026

# High spatial resolution observations of

## NIR

MWC 297,  $d \sim 375$  pc,  
H Be star,  $M \sim 17$  Msun

MWC297B  
Age  $< 1$  Myr  
 $M \sim 0.25$  Msun  
 $A_v \sim 12$  mag

SPHERE@VLT  
coronagraph+XAO

(Ubeira-Gabellini et al., 2020,  
ApJ 890, L8)

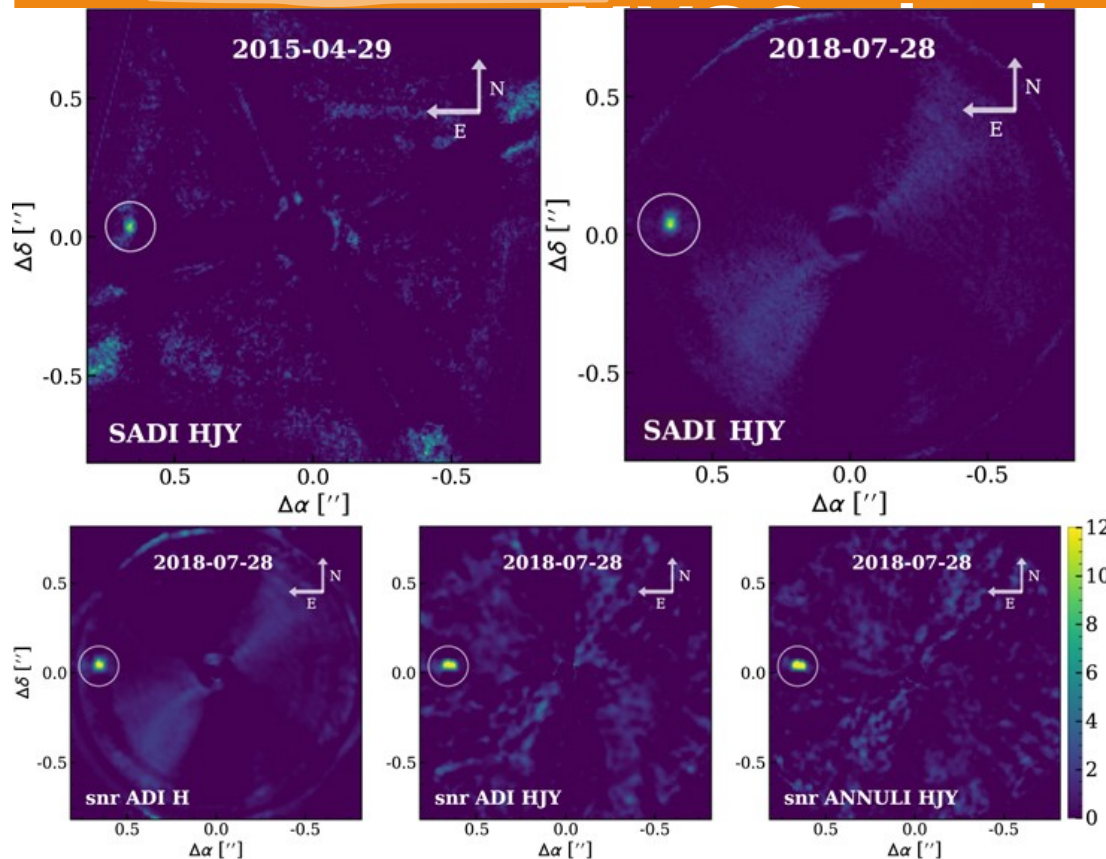

Riccardo's workshop – Florence, May 2026

# High spatial resolution observations of MYSOs in the NIR

**Interferometric observations in the Near-Infrared**

Riccardo's workshop – Florence, May 2026

# High spatial resolution observations of MYSOs in the NIR

Why GRAVITY+ can make a bit easier observing HMYSO

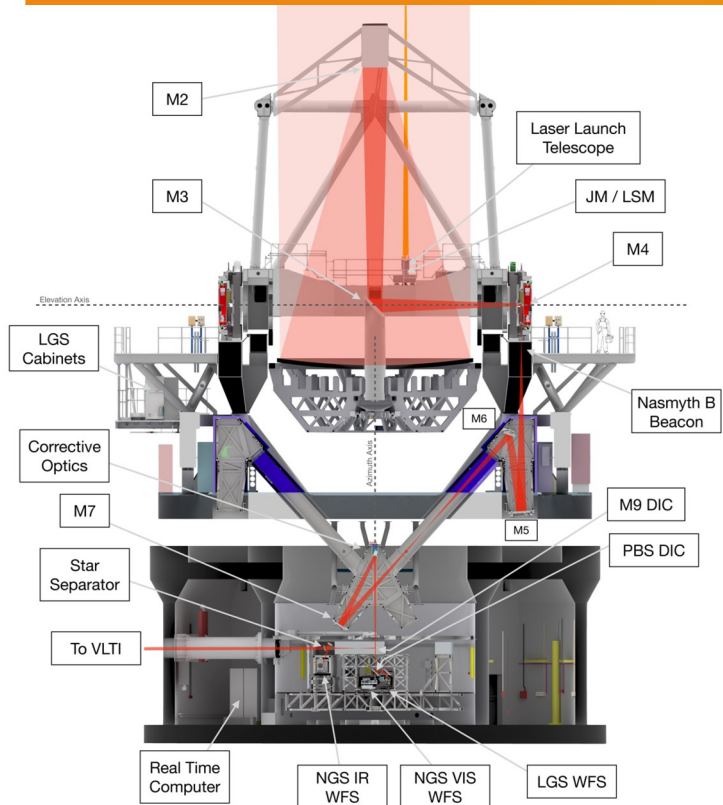

## GRAVITY PLUS ADAPTIVE OPTICS

High-order AO system, Visible AND NIR natural guide star (NGS) and laser guide stars (LGS) on all Uts

Off-Axis fringe tracking (Dual Beam Wide Mode): science target and reference star up to 30" apart

GRAVITY+ COLLABORATION, Abuter et al. 2026, A&A 707, A115

Riccardo's workshop – Florence, May 2026

# High spatial resolution observations of MYSOs in the NIR

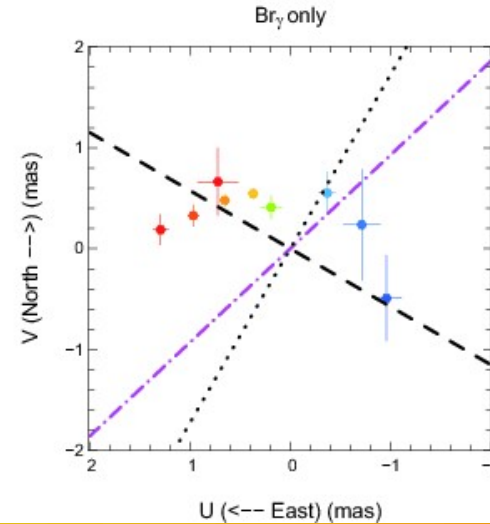
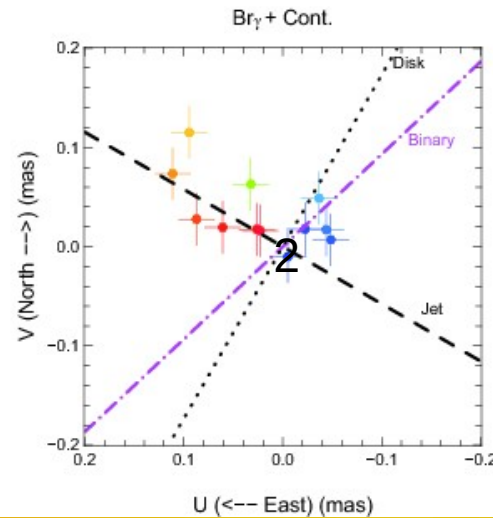
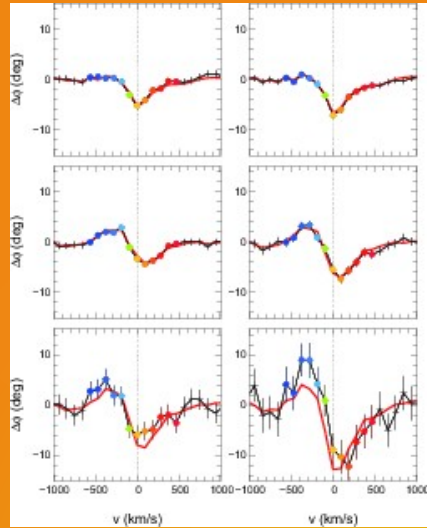

ZCMa AMBER@VLT  
H Be star,  $d \sim 1$  kpc  
Br $\gamma$ , traces jet during outburst phase  
(Benisty et al. 2008, A&A 517, L3)

Riccardo's workshop – Florence, May 2026

# resolution observations of YSOs in the NIR

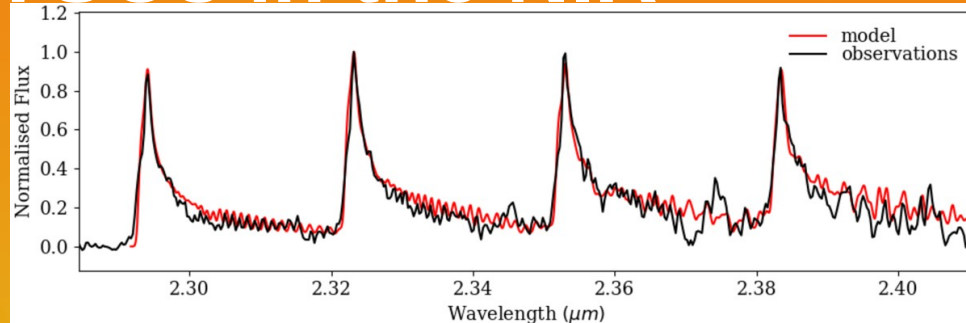
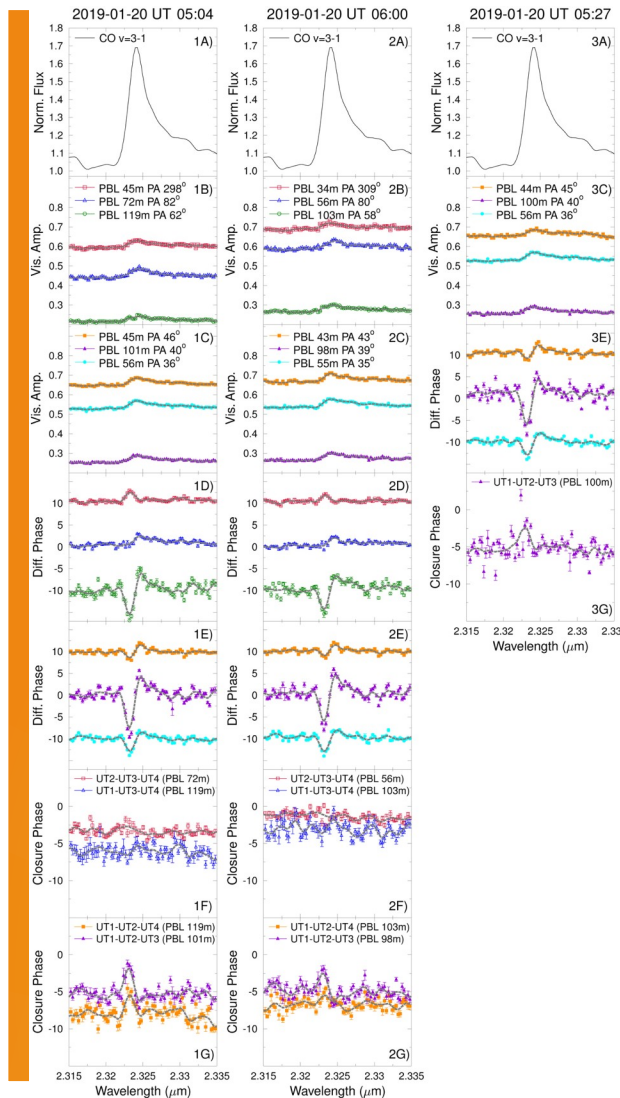

NGC2024 IRS2 - [GRAVITY@VLT](#)

CO overtone (disc tracer)

$d=423$  pc, diameter  $\sim 4$  mas (1.7 au)

$i=34 \pm 1$  deg

Diameter CO emitting region 1.2 au

$VK \sin(i) \sim 84$  km/s

$M^* \sim 14.7$  Msun

(GRAVITY coll., Caratti o Garatti et al. 2020, A&A 635, L12)

Riccardo's workshop – Florence, May 2026

# On observations of the NIR

G033.3891 M~12 Msun d~5 kpc

GRAVITY@VLTI

Bry, CO  
(Koumpia et al. 2024, A&A 690, A209)

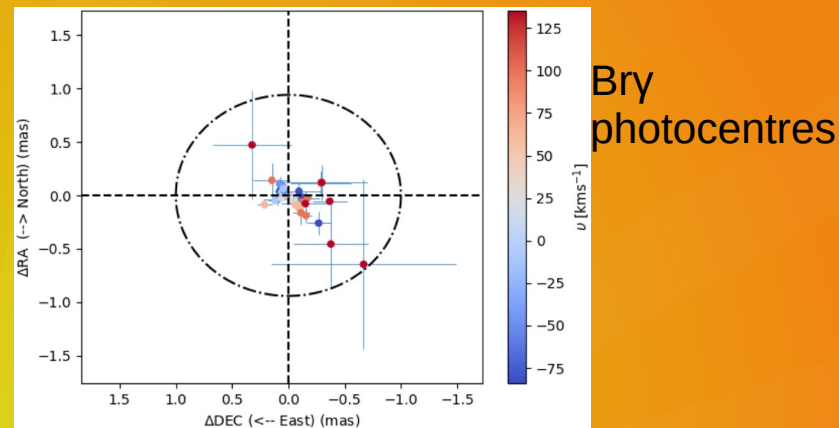
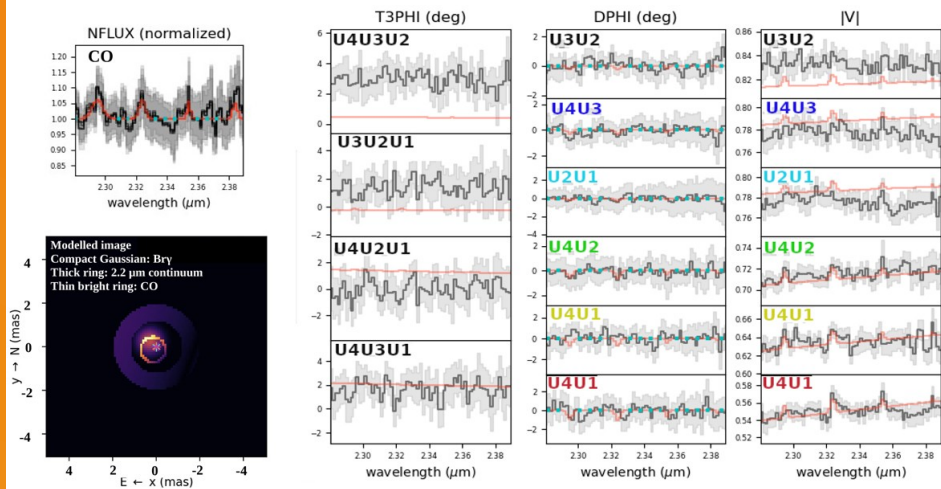
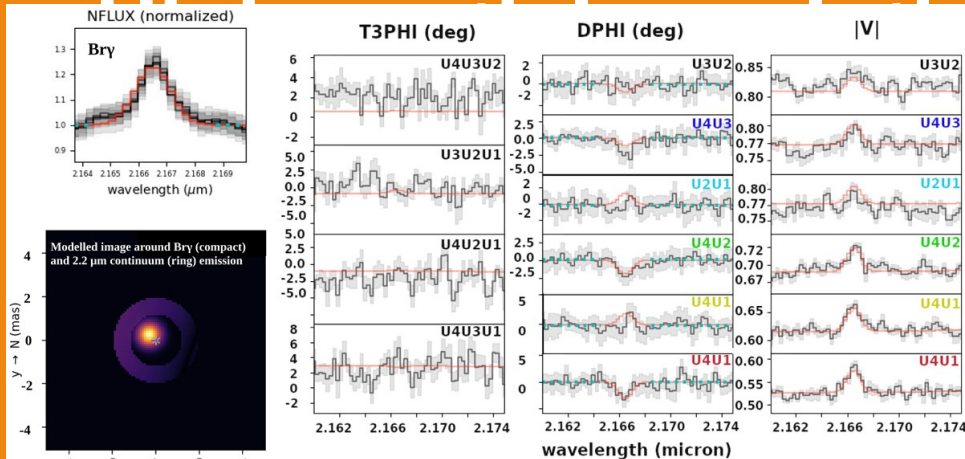

rd's workshop – Florence, May 2026

# High spatial resolution observations of the NIR

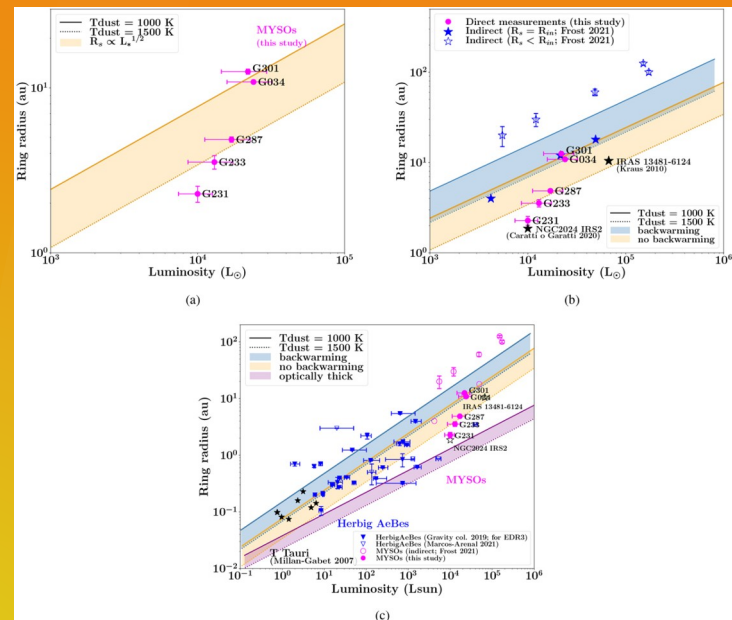
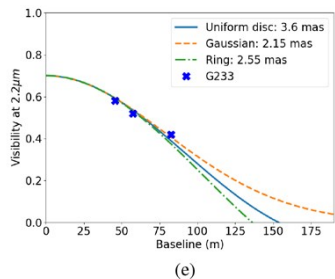
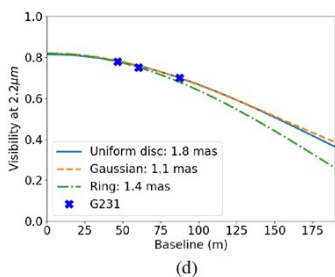
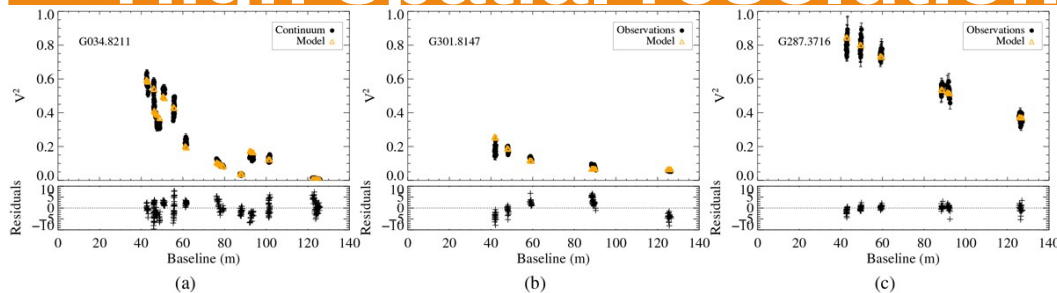

Sample of 6 HMYSOs  
(9 – 16  $M_{\text{sun}}$ ; 1.6 to 4.5 kpc)

AMBER, GRAVITY@VLTI  
Koumpia et al. 2021, A&A 654, A109

Riccardo's workshop – Florence, May 2026

# High spatial resolution observations of MYSOs in the

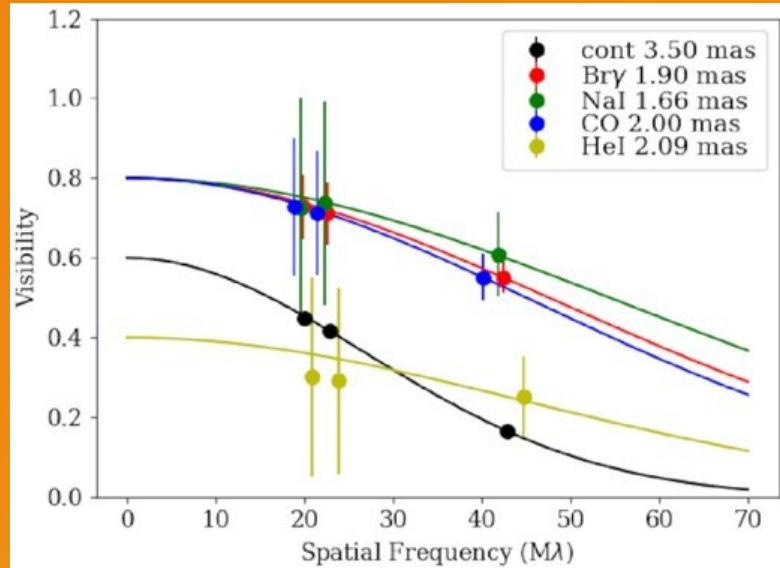

IRAS13481-6124  $d \sim 3.6$  kpc  $L \sim 7.7 \times 10^4$   $L_{\text{sun}}$   
 $M \sim 18 M_{\text{sun}}$   
 (Koumpia et al. 2023, MNRAS 519, L51)

Nal

HeI

