

From flares to the corona: Python tools and *catalogues* for cross-instrument connectivity

Laura A. Hayes

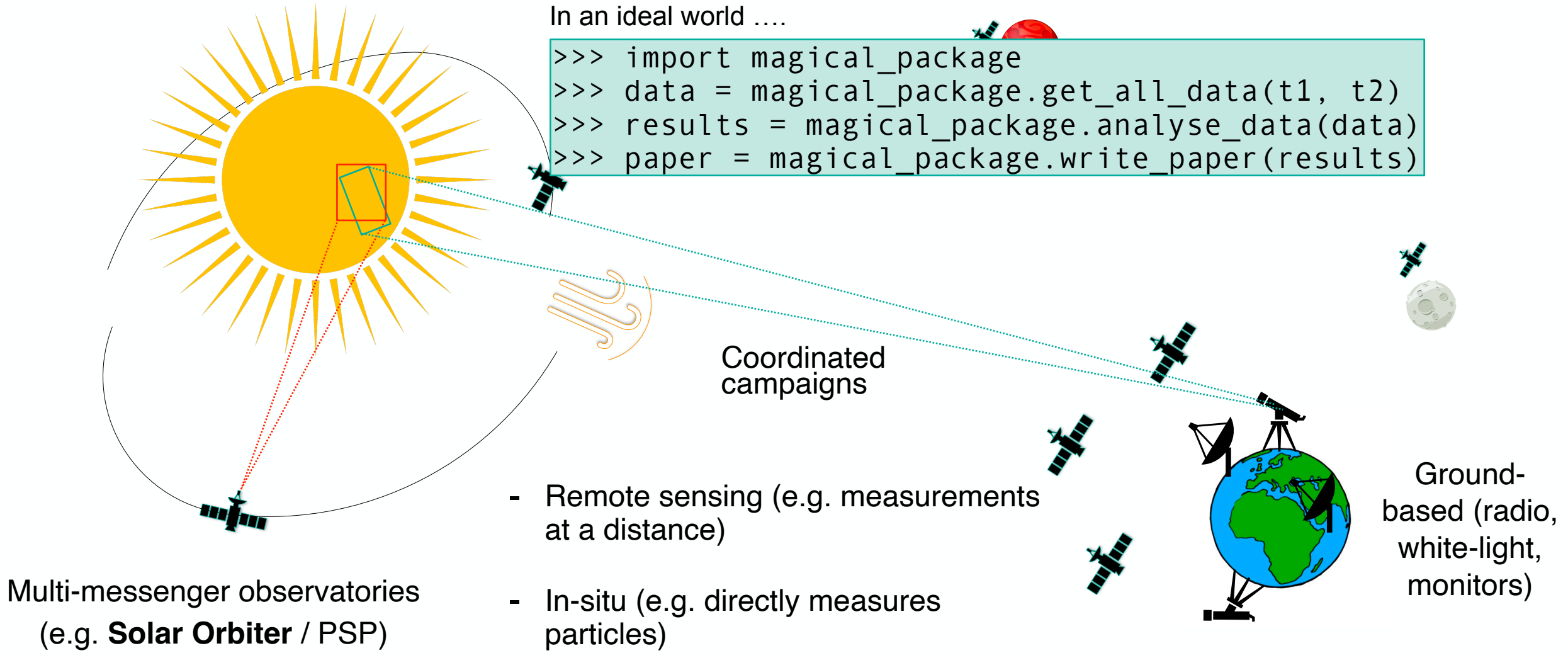

Diverse Data Landscape in Heliophysics



Diverse Data Landscape in Heliophysics

In an ideal world

```
>>> import magical_package  
>>> data = magical_package.get_all_data(t1, t2)  
>>> results = magical_package.analyse_data(data)  
>>> paper = magical_package.write_paper(results)
```

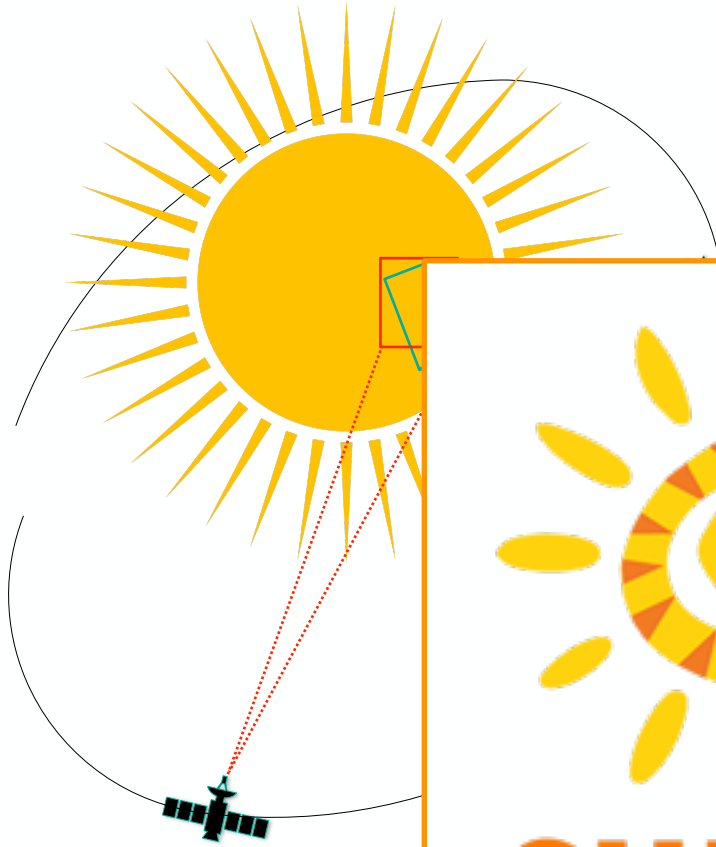

Modelling and Data Analysis Working Group (MADAWG) SoIO Python Working Group

Multi-messenger observations (e.g. **Solar Orbiter** / PSR)

Ecosystem

ly measures

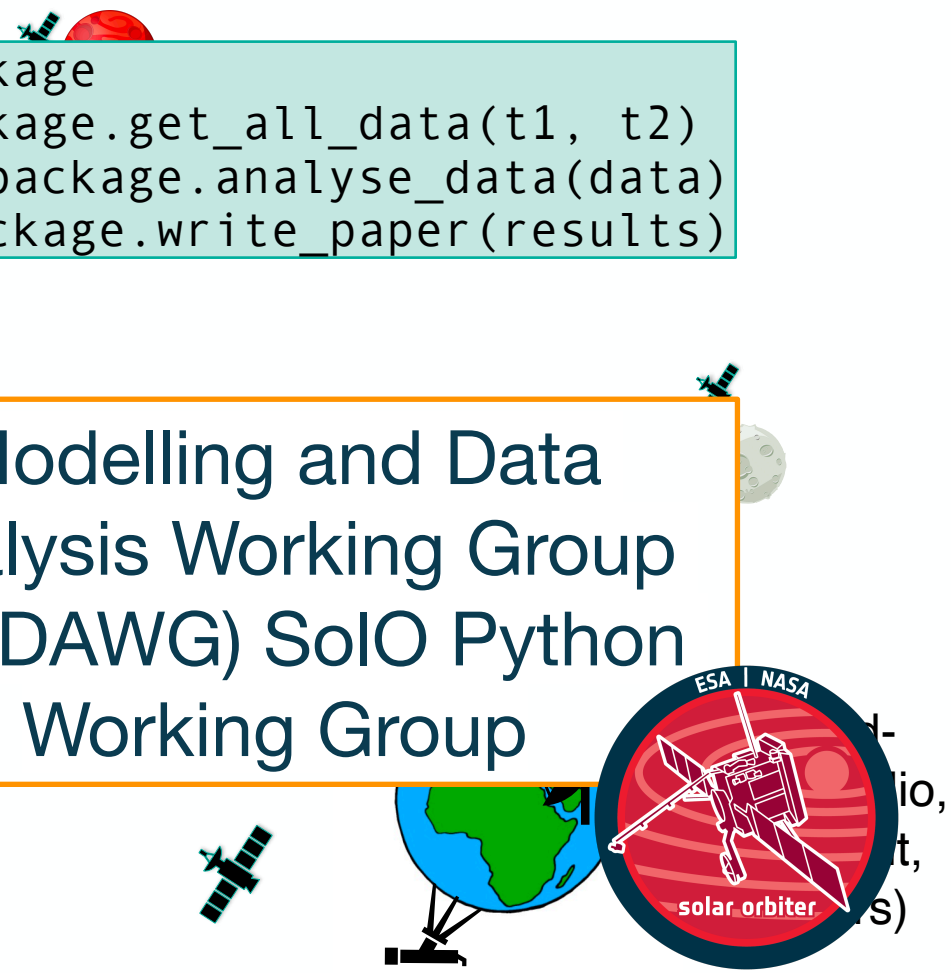

Solar Orbiter as a System Mission

Designed for coordinated science across the Sun–heliosphere system

- 6 Remote sensing + 4 in-situ in one mission
- Multiple viewpoints on the same phenomena
- Links solar activity to heliospheric response
- Built for coordinated campaigns (SOOPs)

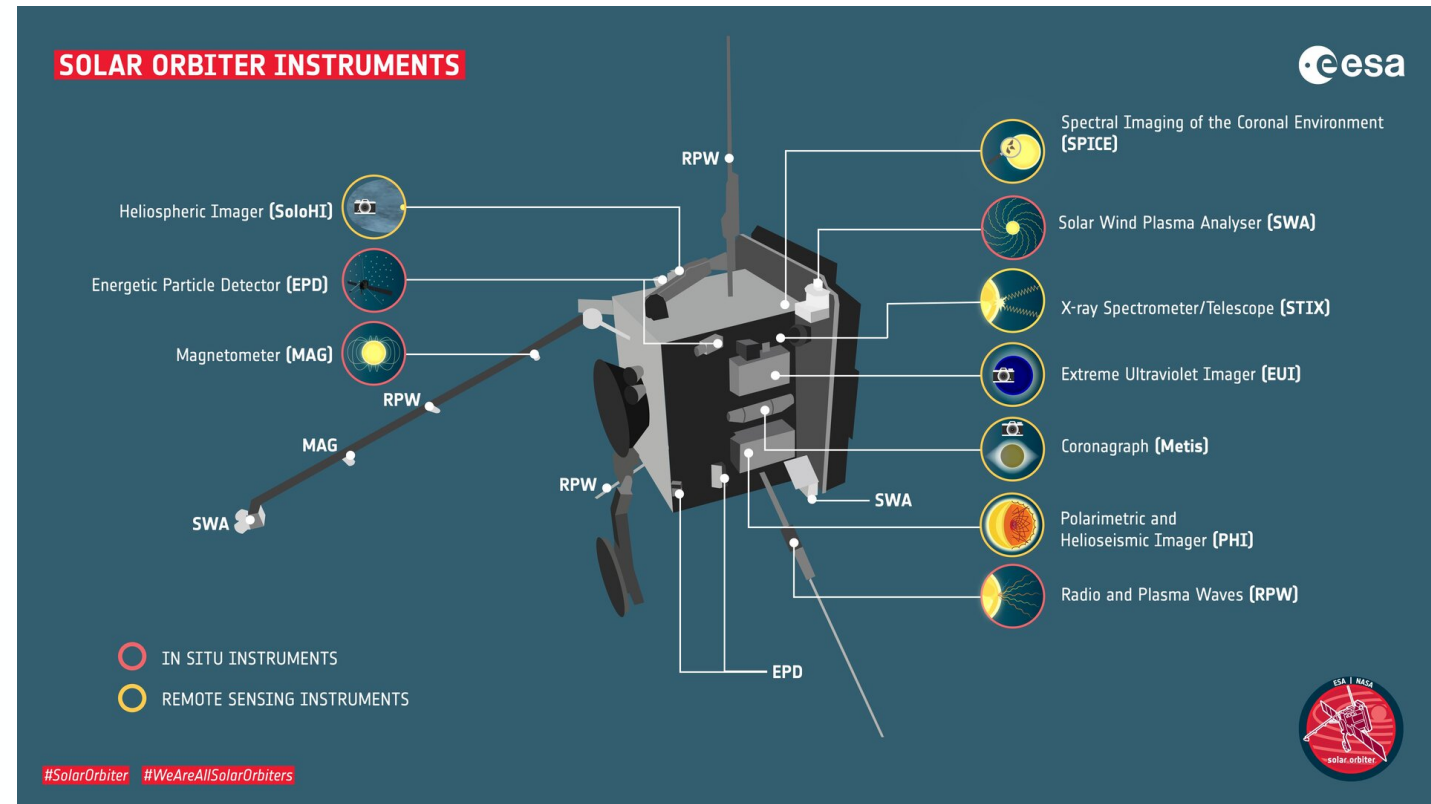

In practice, analysis is often still instrument-by-instrument.

The Practical Challenges with Solar Orbiter

Multi-instrument science is hard in practice

• Finding relevant data

- When data is available
- SOOPs and observing modes
- Coverage gaps
- Coordinate systems
- Time matching between instruments

• Working with that data

- Analysis tools different for working with multiple instruments
- Knowledge siloed in different places

Solar Orbiter data availability

Last updated 2026-02-12, daily resolution, all data available at the [Solar Orbiter Archive](https://solar-orbiter.esac.esa.int)

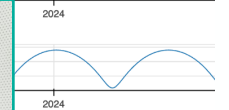

ar.esac.esa.int

Why Catalogues Matter

Event catalogues + data availability catalogues = infrastructure

Event Catalogues

- Define events consistently
- Standard times & location
- Cross instrument reference points
- Enable statistics and surveys
- Shared event definitions

e.g. HEK

Data Availability Catalogues

What data exists?

- Which instruments observed
- When data is available
- Coverage and gaps
- Observing modes/SOOPs
- Helps plan studies

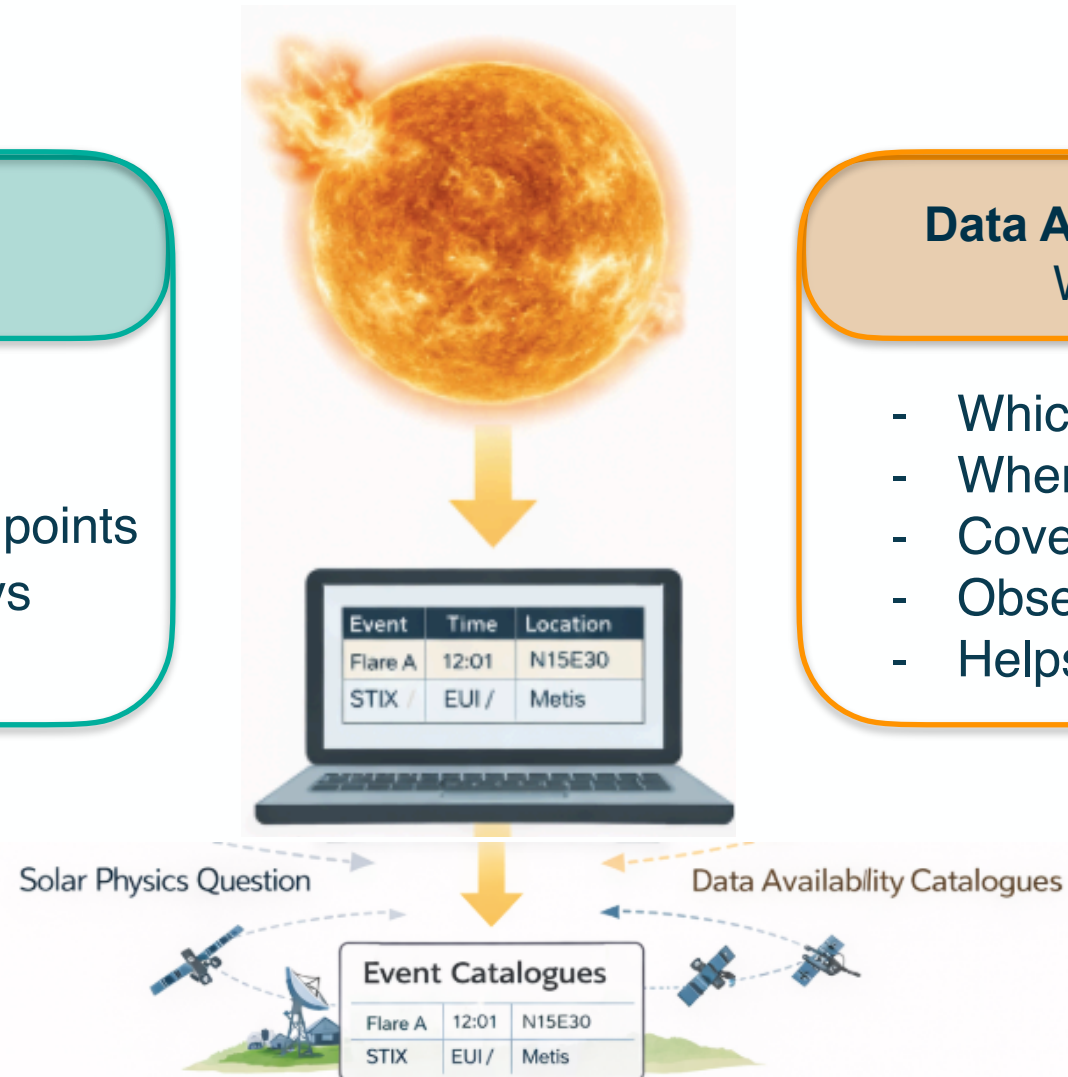

STIX as an example

Example of STIX flare catalogue

Spectrometer Telescope for Imaging X-rays (STIX):

- X-ray imaging spectroscopy (*indirect* imaging)
- 4-150 keV energy range, 0.5 s cadence
- Low telemetry (further reduced by on-board binning)
- Continuously observing, and has been since 2021

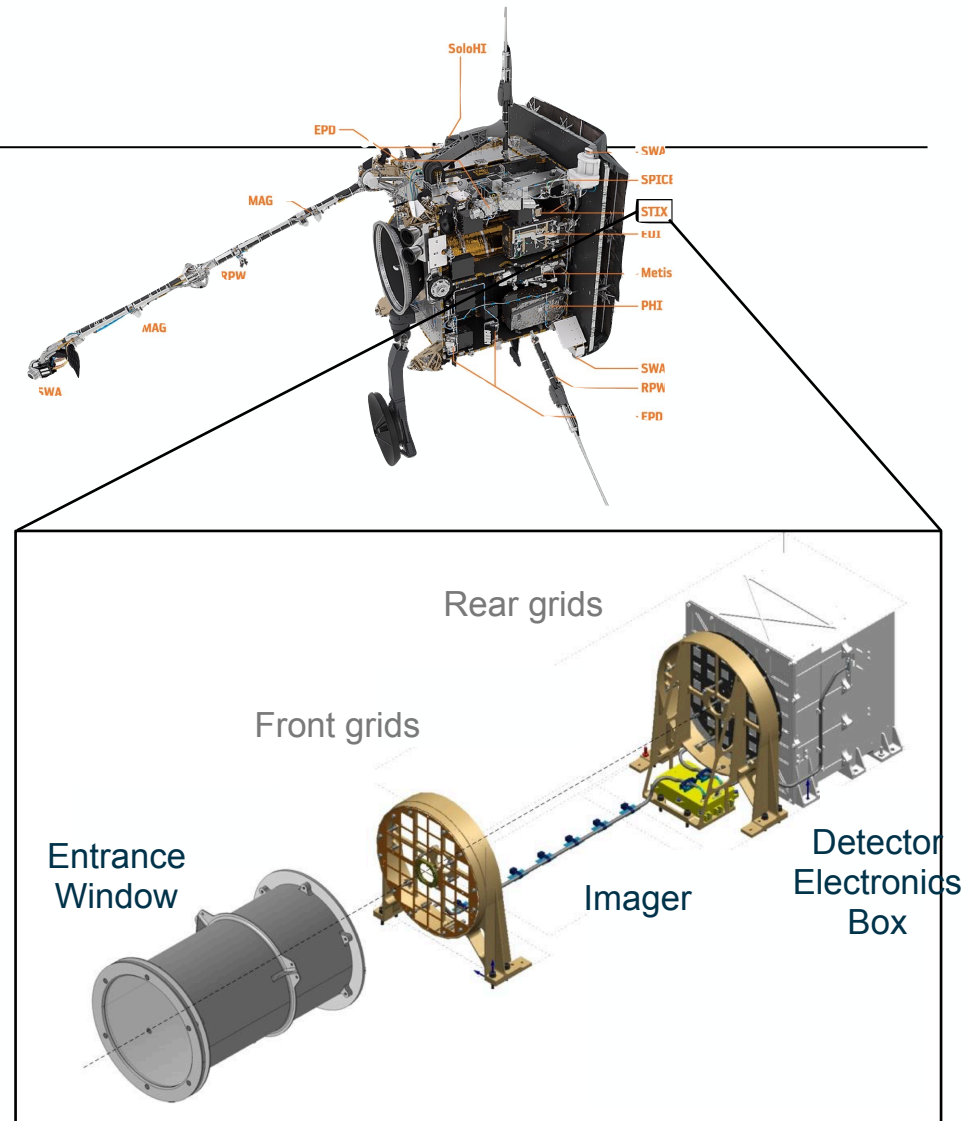
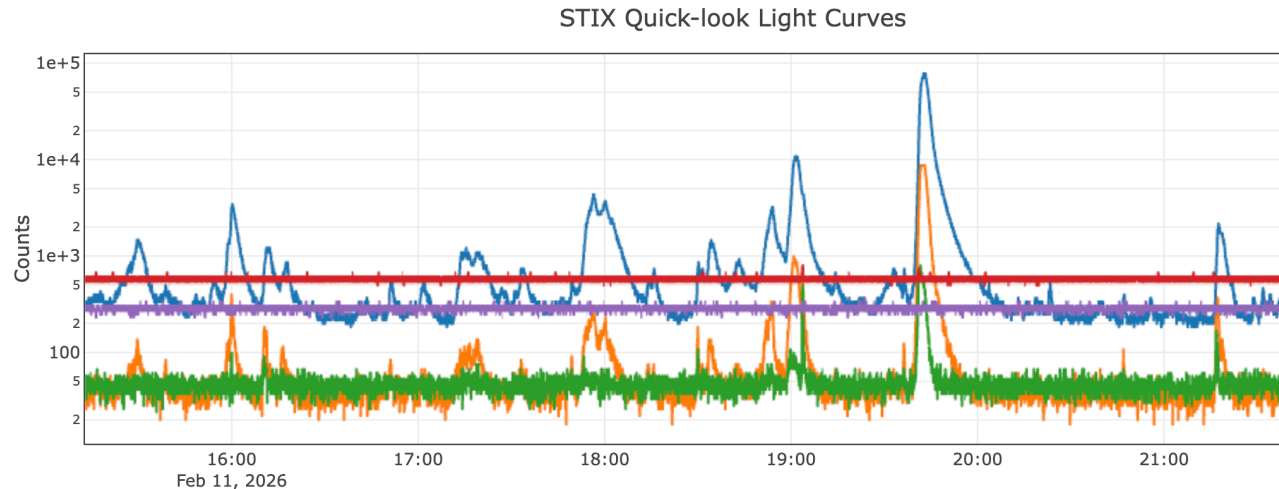

See Krucker et al. 2020,

STIX flares : 5 years of observations

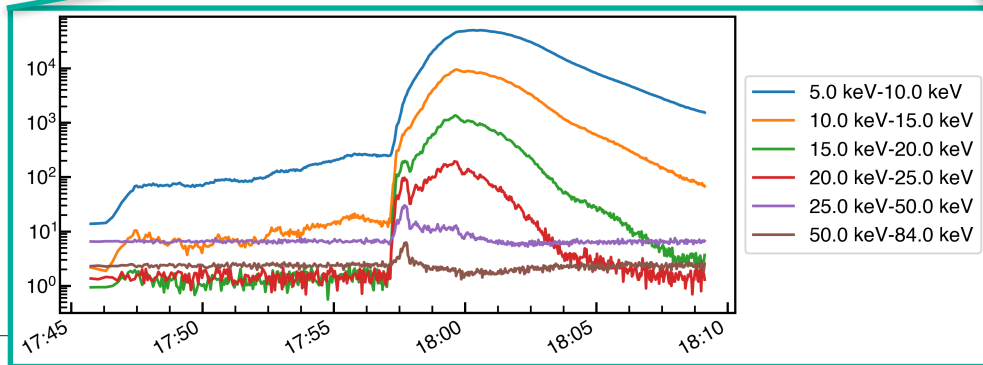
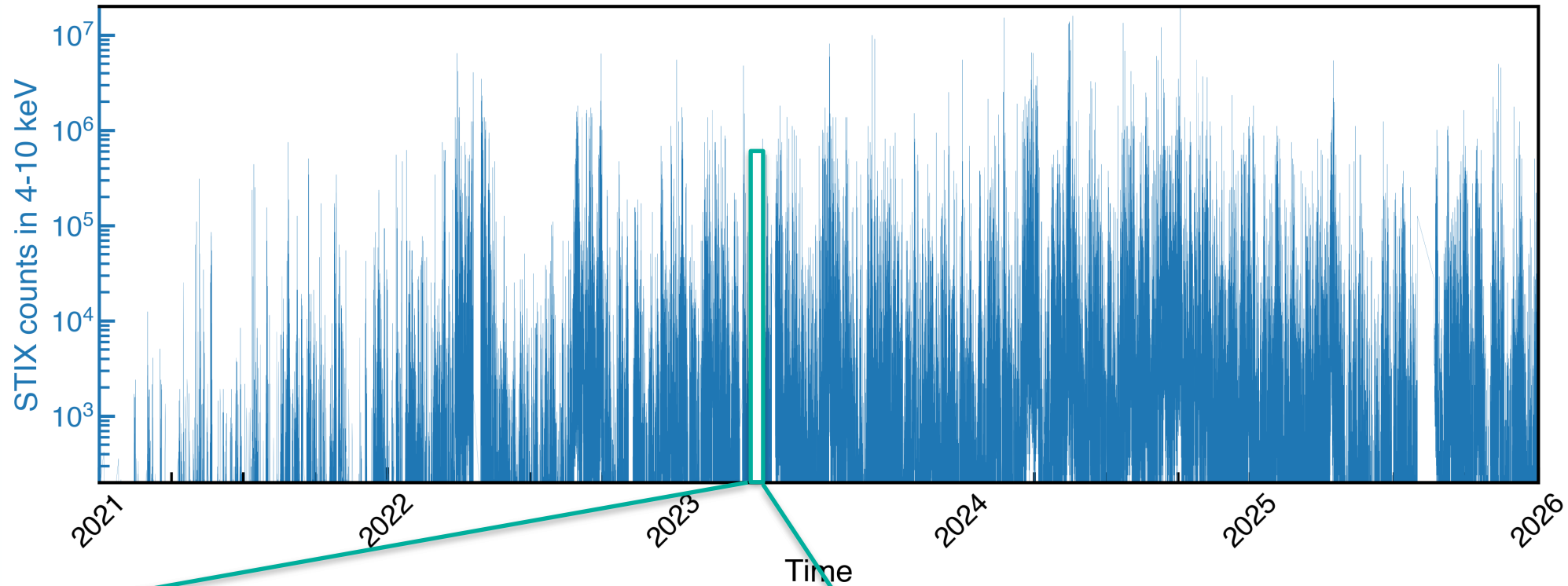

STIX has observed > 90,000 flares since January 2021

STIX flares : 5 years of observations

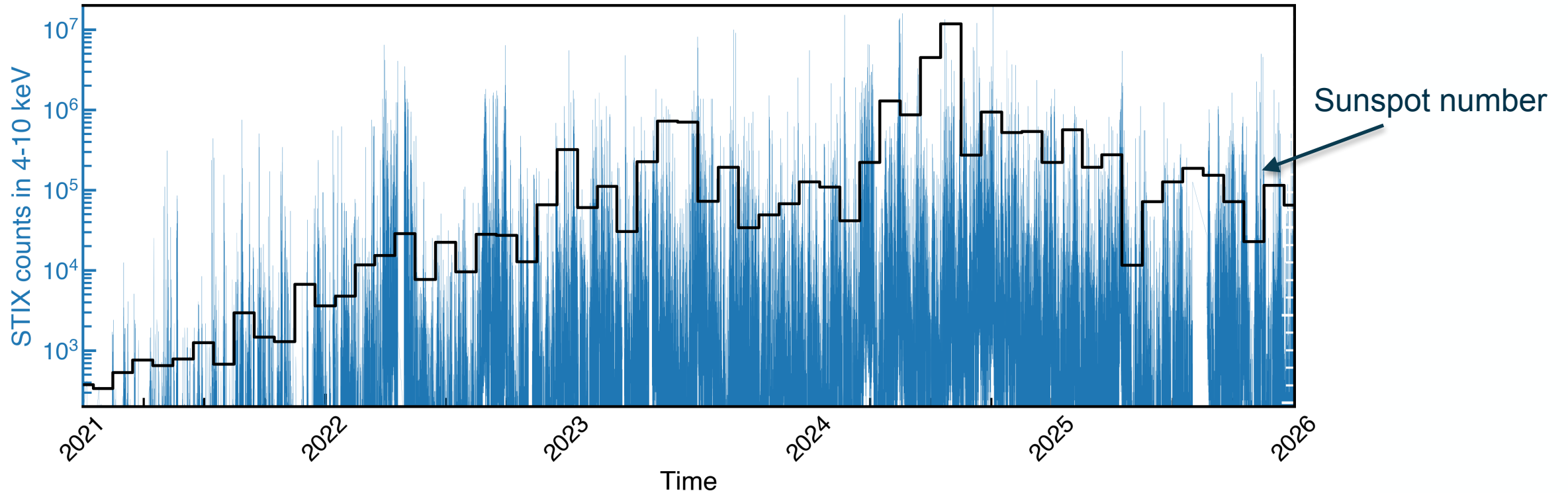

STIX has observed > 90,000 flares since January 2021

Over half solar cycle of observations to date

STIX flares : Generating science flarelist with locations

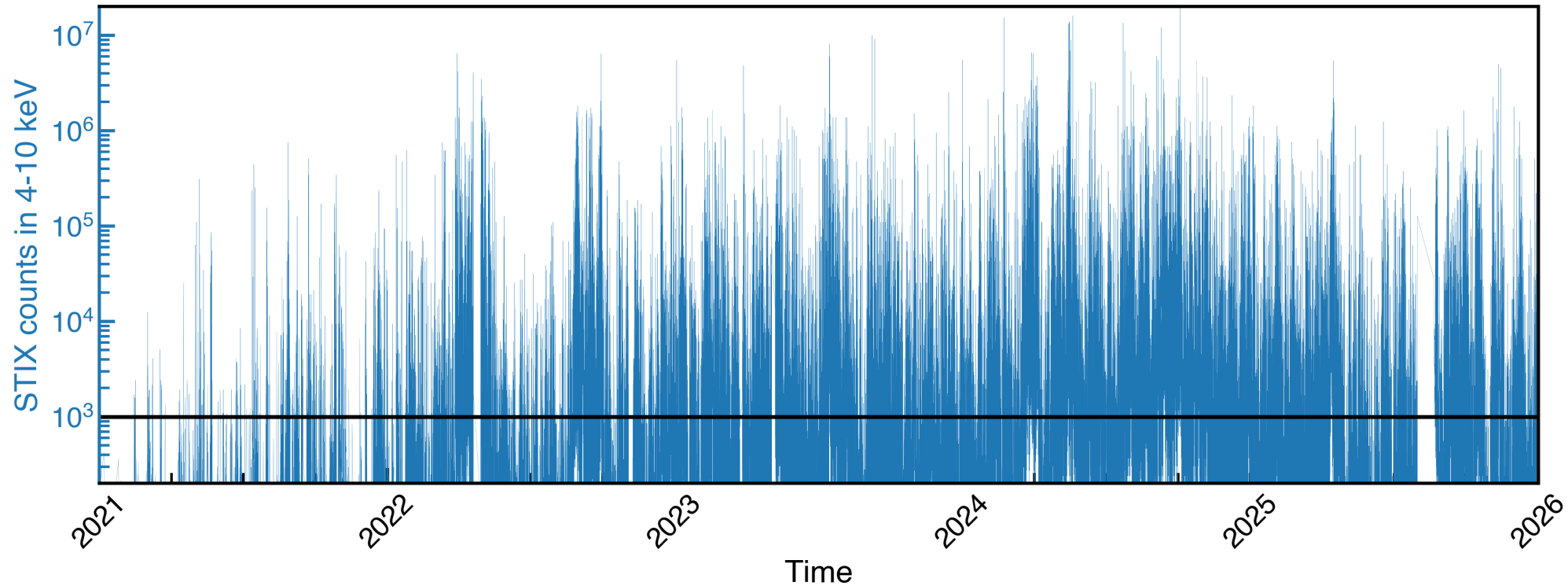

STIX has observed > 90,000 flares since January 2021

Over half solar cycle of observations to date

Look at flares > 1000 counts → 31000 flares

STIX flares : Generating science flarelist with locations

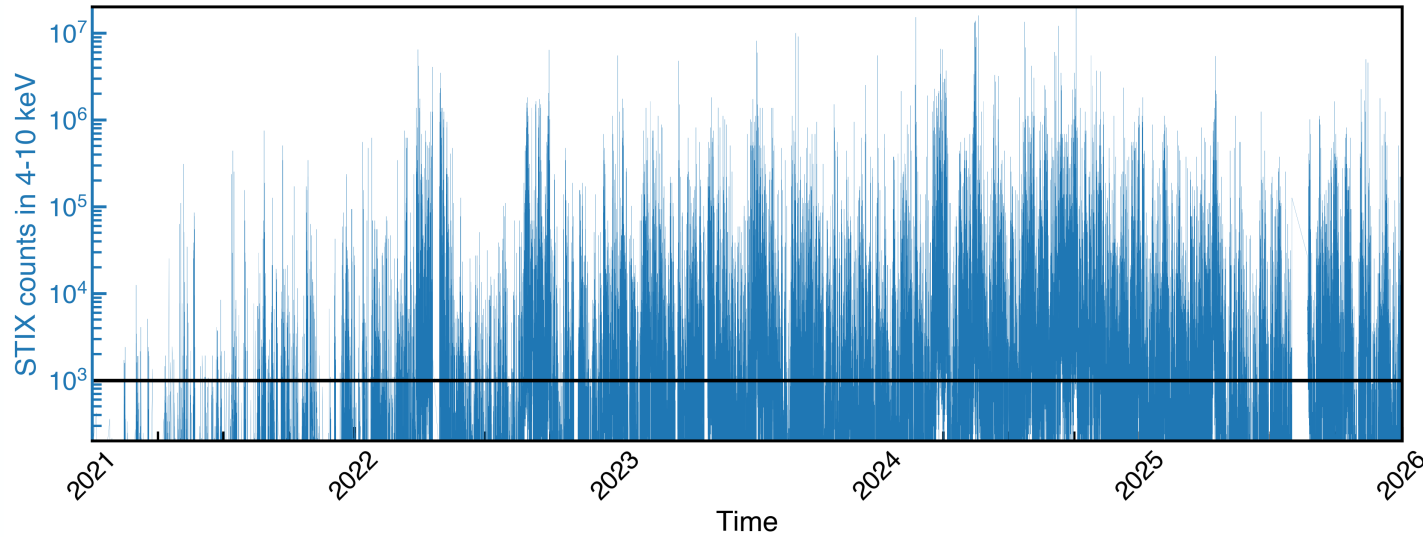

Look at flares > 1000 counts \rightarrow 31000 flares

- Find pixel data (cpd) data that contains the peak of the flare
- Make image at peak (40s integration) over 4-16 keV to find location

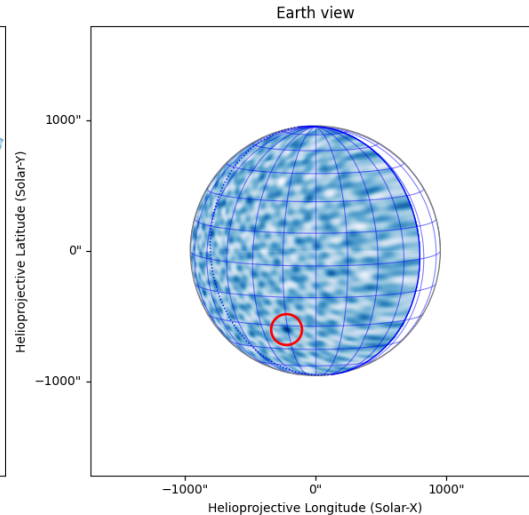
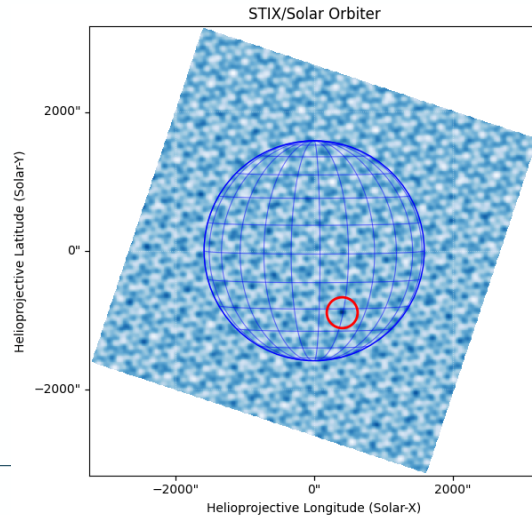

- Provide coordinate of this on Sun from SoLO and do coordinate transforms to different frames (e.g. HPC at earth/solo, HGC)



STIX flares : Generating science flarelist with locations

>>> stixflarelist

start.UTC	end.UTC	peak.UTC	4-10 keV	10-15 keV	15-25 keV	25-50 keV	50-84 keV	hpc_x_solo	hpc_y_solo	hpc_x_earth	hpc_y_earth	visible_from_earth	hgs_lon	hgs_lat	hgc_lon	hgc_lat
2021-08-28T03:37:16.568	2021-08-28T04:25:40.573	2021-08-28 04:04:28.570	2431	247	99	927	543	1337.578646	-724.968619	73.374314	-548.045317	True	5.001941	-28.007349	6.983355	-28.007349
2021-08-28T05:44:56.581	2021-08-28T05:49:52.581	2021-08-28 05:47:48.581	43007	5375	735	863	495	1365.932781	-688.211838	103.609631	-526.343197	True	6.972907	-26.450864	8.006245	-26.450864
2021-08-28T05:43:24.581	2021-08-28T06:58:52.589	2021-08-28 06:04:24.583	753663	77823	7935	1215	543	1373.382667	-685.250874	124.889223	-524.087126	True	8.404499	-26.313763	9.285534	-26.313763
2021-08-28T06:54:08.588	2021-08-28T06:57:20.588	2021-08-28 06:55:20.588	77823	5375	671	1087	543	1237.517733	-792.571069	-59.958867	-587.031344	True	-4.205435	-30.918888	356.208292	-30.918888
2021-08-28T07:33:48.592	2021-08-28T07:37:00.592	2021-08-28 07:34:52.592	2943	215	91	927	495	1360.951526	-716.546498	134.870047	-541.453260	True	9.186413	-27.589509	9.237425	-27.589509
2021-08-28T08:17:44.596	2021-08-28T09:16:52.602	2021-08-28 08:41:44.599	15871	1343	271	927	543	1361.039338	-673.980046	67.488459	-518.733263	True	4.512425	-25.865772	3.949945	-25.865772

↑
Times of flares
(at UTC Solar
Orbiter)

↑
Fluxes in
energy bands

↑
Location of flare
from Solar Orbiter

↑
Location of flare
from Earth

↑
Stonyhurst +
Carrington coords
too

The STIX flare catalogue

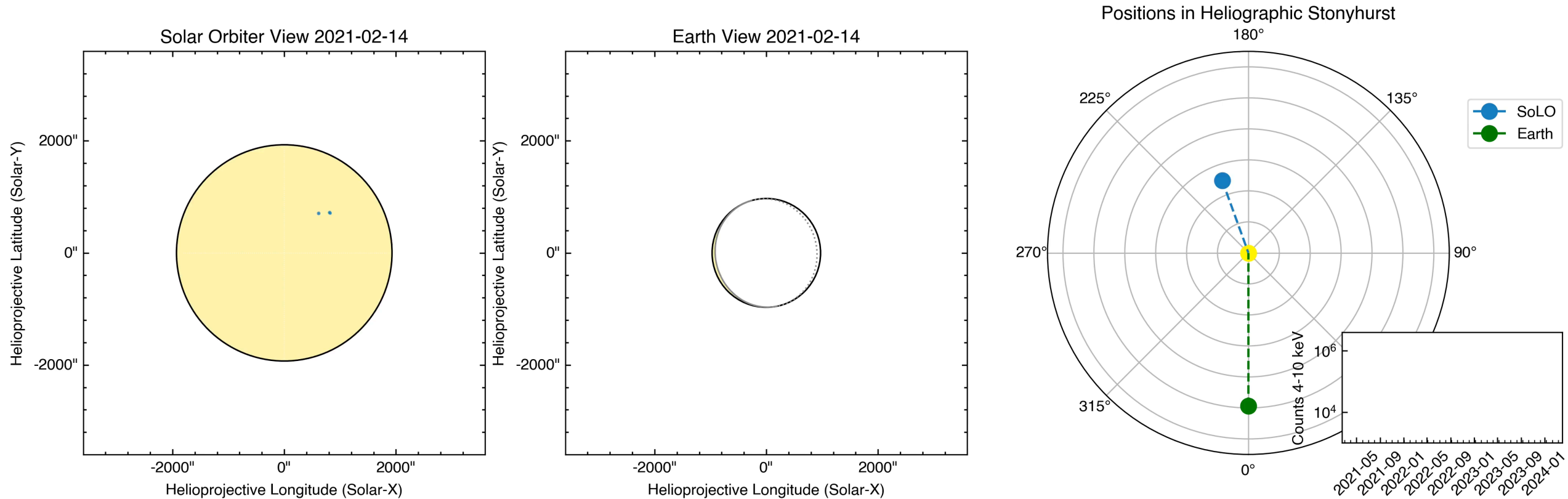

What This Enables

2021-01-01

180°

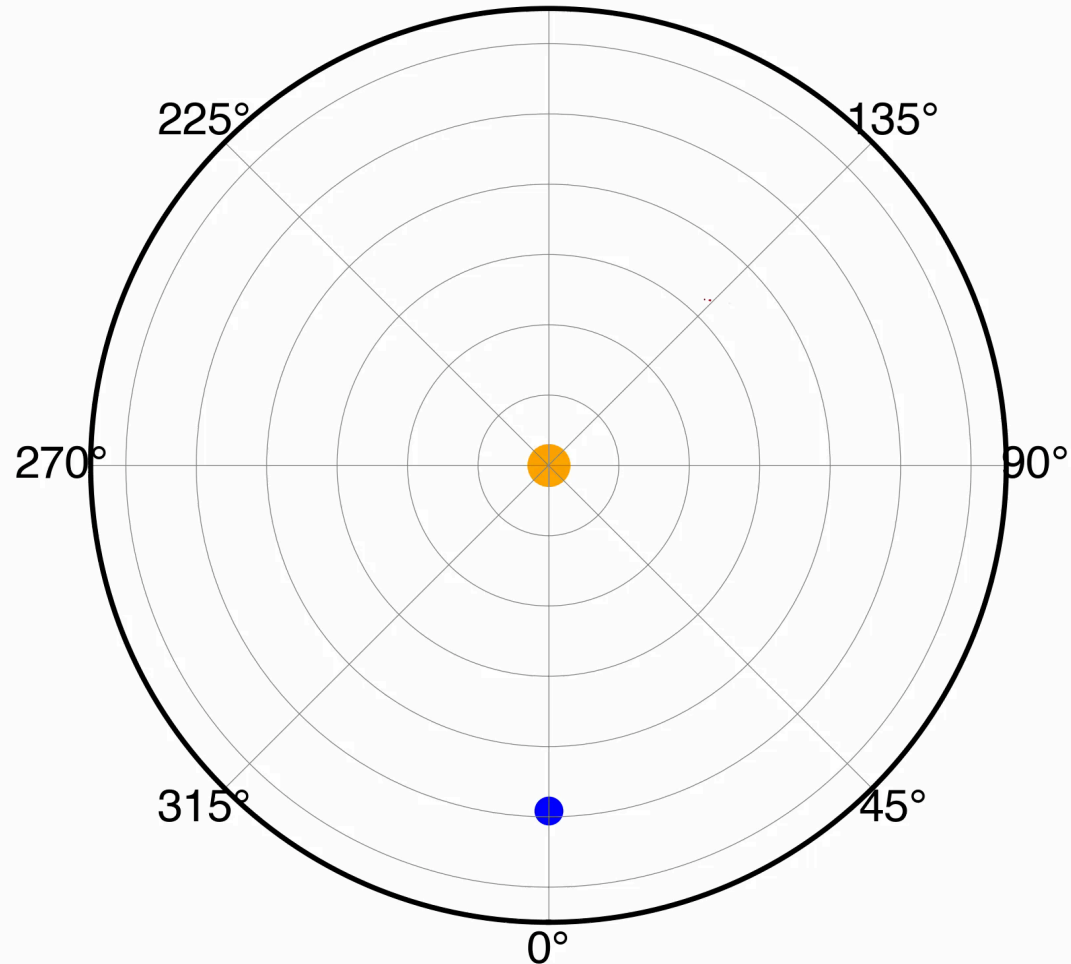

- Find events cross Solar Orbiter instruments (e.g. STIX + EU1)

- CoSEE-CAT solar energetic electron (SEE) events on Solar Orbiter

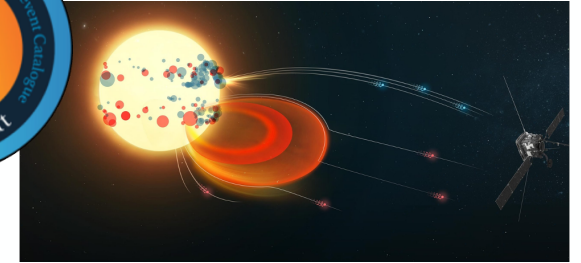

- Compare with Earth flares

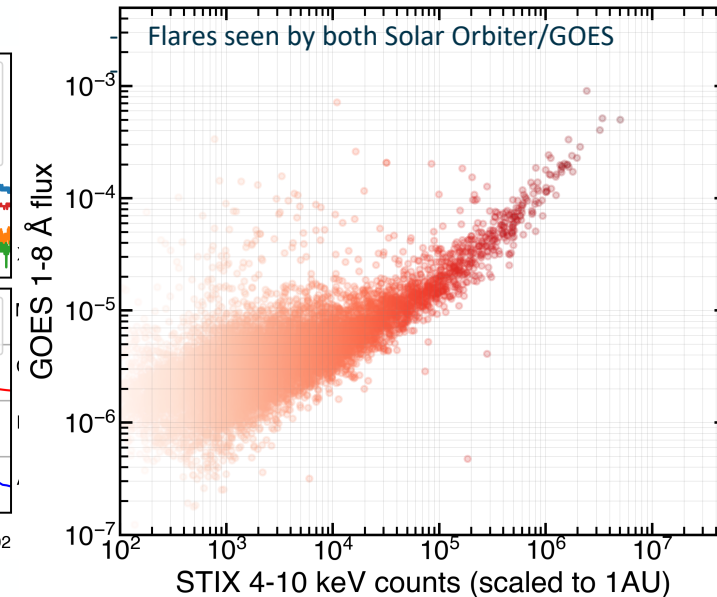
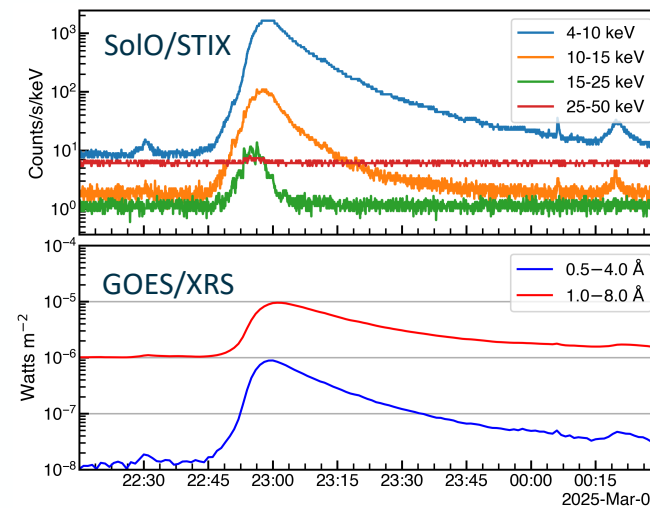

- From STIX 4-10 keV energies - can estimate the GOES X-ray fluxes and measure proxies for GOES classes - estimate flare sizes on backside Sun

METIS catalogue + finding events

METIS CME list <https://metisarchive.oato.inaf.it/cme/list>



Cme_Id	Date	Time_beg	Time_end	VL channel	UV channel	VL cadence	UV cadence	Rmin	Rmax	CPA	Width	L_Speed	SC_Pos
20231231.104442.300	2023-12-31	2023-12-31 10:44:42	2023-12-31 15:44:42	Y	N	0	0	5.72	12.15	300	63	482	
20231231.044442.218	2023-12-31	2023-12-31 04:44:42	2023-12-31 08:44:42	Y	N	0	0	5.72	12.15	218	69	293	
20231231.094442.166	2023-12-31	2023-12-31 09:44:42	2023-12-31 13:02:26	Y	N	0	0	5.72	12.15	166	26	450	
20231230.134442.107	2023-12-30	2023-12-30 13:44:42	2023-12-30 20:44:42	Y	Y	0	0	5.71	12.14	107	102	267	
20231229.024851.105	2023-12-29	2023-12-29	2023-12-29	Y	N	0	0	5.7	12.12	105	60	800	

The METIS CME catalogue is extremely valuable on its own, but its value increases even more when it can be linked to disk activity and flare catalogues.

For example can be combined with STIX to make flare-CME list!

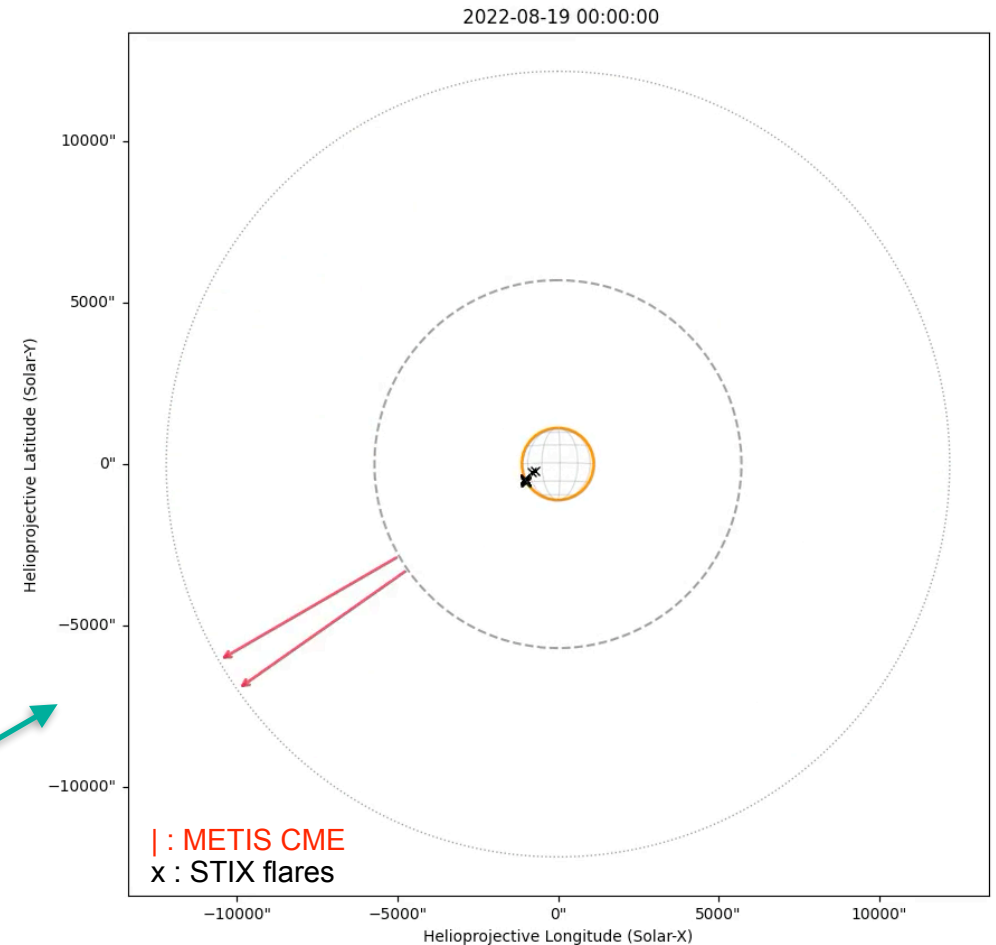

Cross-instrument catalogues multiply the value of instrument-specific catalogues

The SunPy Ecosystem and MADAWG Python WG



sunpy core vs
SunPy ecosystem

The SunPy Ecosystem

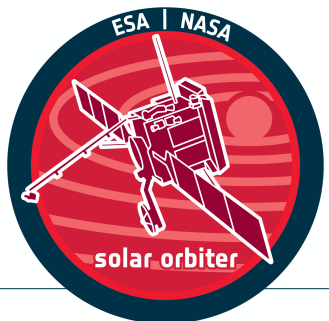
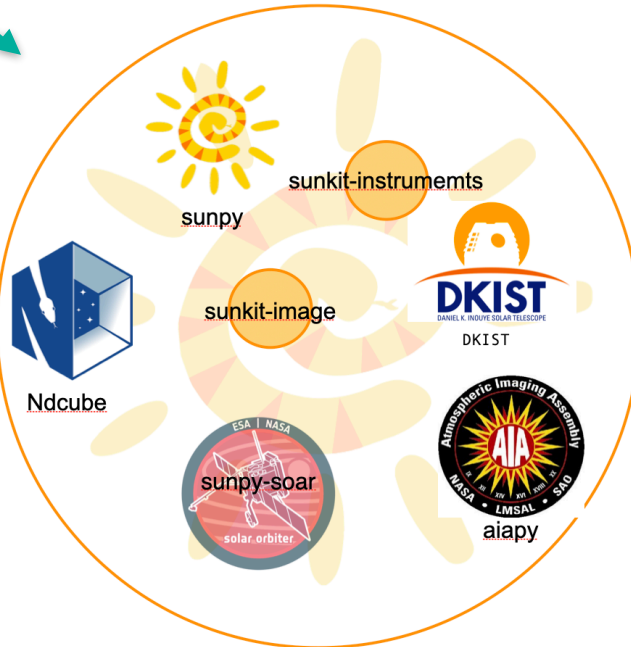

Lots of Functionality Already Exists Than We Realise

- Data access (Fido, VSO, SOAR interfaces)
- Coordinate transformations
- Map & time series containers
- Multi-mission compatibility
- Plotting & quick-look tools

**The challenge is often
discoverability and tailoring to
Solar Orbiter use cases.**

Solar Orbiter MADAWG Python WG

MADAWG Python Working Group Aims

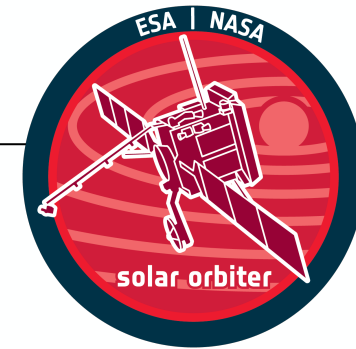

Modelling and Data Analysis (MADAWG) Working Group

Led by Clementina Sasso, Giovanna Jerse, Laura Hayes

1. Centralise existing Solar Orbiter Python tools & efforts

- Single hub, shared visibility, centralise codes, docs, workflows

2. Scope out needs → identify missing tools & data gaps

- Bring teams together → coordinate across instruments

3. Develop document common tools

- *Catalogues*, data containers, overview plots within SunPy ecosystem

4. Facilitate access to data → smooth integration with SOAR & SunPy

Enable science → provide user-ready analysis workflows

MADAWG Python Working Group Aims

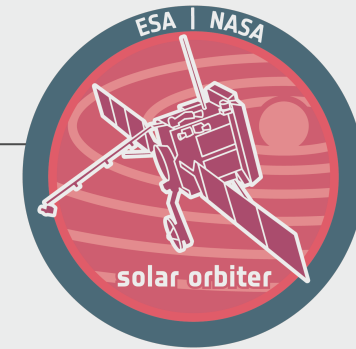

Modelling and Data Analysis (MADAWG) Working Group

Led by Clementina Sasso, Giovanna Jerse, Laura Hayes

1. Centralise existing Solar Orbiter Python tools & efforts

- Single hub, shared visibility, centralise codes, docs, workflows

2. Scope out needs → identify missing tools & data gaps

- Bring teams together

3. Develop document com

- *Catalogues*, data contain

4. Facilitate access to data

Enable science →

Towards Light Standards for Solar Orbiter Catalogues?

- Do we want a light common template?

For example:

- Minimum metadata fields
- Time & coordinate conventions
- Instrument visibility flags
- Event IDs



MADAWG Python Working Group

<https://solar-orbiter-docs.readthedocs.io/>

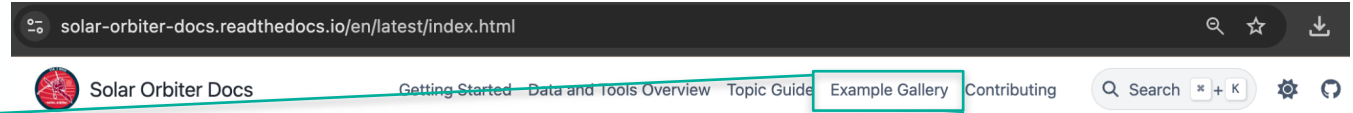

- Sur
- ava
- No
- Cor
- Ide
- doc
- cata
- soft
- Buil
- Rea

Example Gallery

This gallery contains Python scripts demonstrating how to work with Solar Orbiter data. The examples are auto-generated from Python scripts in this directory.

See here for more details on how they should be structured: <https://sphinx-gallery.github.io/stable/syntax.html>

<p>Finding and Plotting Solar Orbiter MAG Data</p>	<p>Finding and Plotting EU Data</p>	<p>Plotting the Solar Orbiter Trajectory</p>	<p>Finding and Plotting PHI Data</p>	<p>Plot PHI Blobs overlay on EU maps</p>
<p>Get PHI Data Noise Levels</p>	<p>Get PHI Polarisation Maps</p>	<p>Disambiguation of SO/PHI data and magnetic field Heliographic components</p>	<p>Reproject PHI Blobs to CEA</p>	<p>WCS coordinates in SO/PHI-HRT Data</p>

Solar Orbiter Data Documentation

to the Solar Orbiter Data Documentation! 🚀

community-driven effort to provide guides, examples, and resources for working with Solar Orbiter data in using the [SunPy](#) ecosystem.

Documentation is part of the Solar Orbiter Modelling and Data Analysis Working Group (MADAWG) "Python Working Group" which aims to support and promote the use of Python tools for Solar Orbiter data analysis.

<p>Getting Started</p> <p>Learn how to install dependencies and get started with Solar Orbiter data.</p> <p>To the Getting Started Guide</p>	<p>Analysis Tools</p> <p>Tools for analyzing Solar Orbiter data using SunPy and other Python packages.</p> <p>To the Analysis Tools</p>
<p>Example Gallery</p> <p>View interactive examples demonstrating Solar Orbiter data analysis.</p>	<p>Contribute to the Docs</p> <p>Help improve this documentation by adding examples, fixing typos, or suggesting new content.</p>

<https://github.com/SolarOrbiterWorkshop/solar-orbiter-docs>

Take aways and next steps



Missions make the data.
Software and community make the science.

- Solar Orbiter was designed as a system observatory
- Cross-instrument catalogues turn multi-instrument data into system science
- The SunPy ecosystem & community packages make this scalable and reproducible
 - **software is core infrastructure, like telescopes.**
- Many building blocks already exist, discoverability and coordination are key

+ 5 years of observations + more to come, exciting time ahead for Solar Orbiter science
If anyone is interested in getting involved and contributing - please do!